

MH 1C - MH 2C - MH 2M

Instructions for use

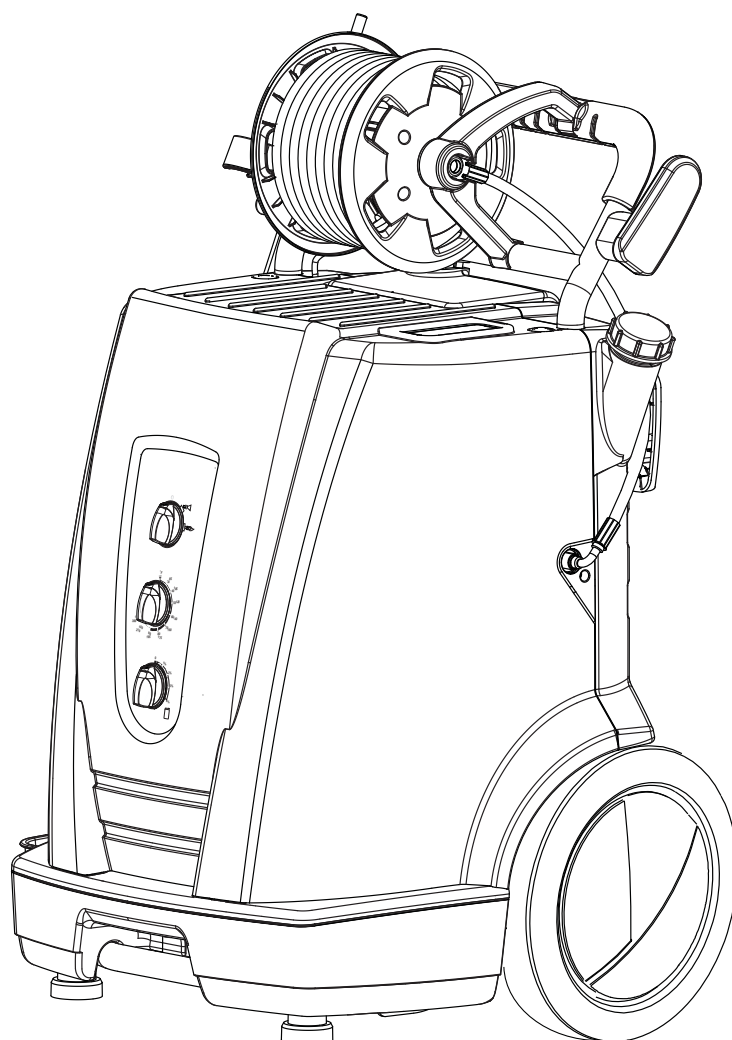

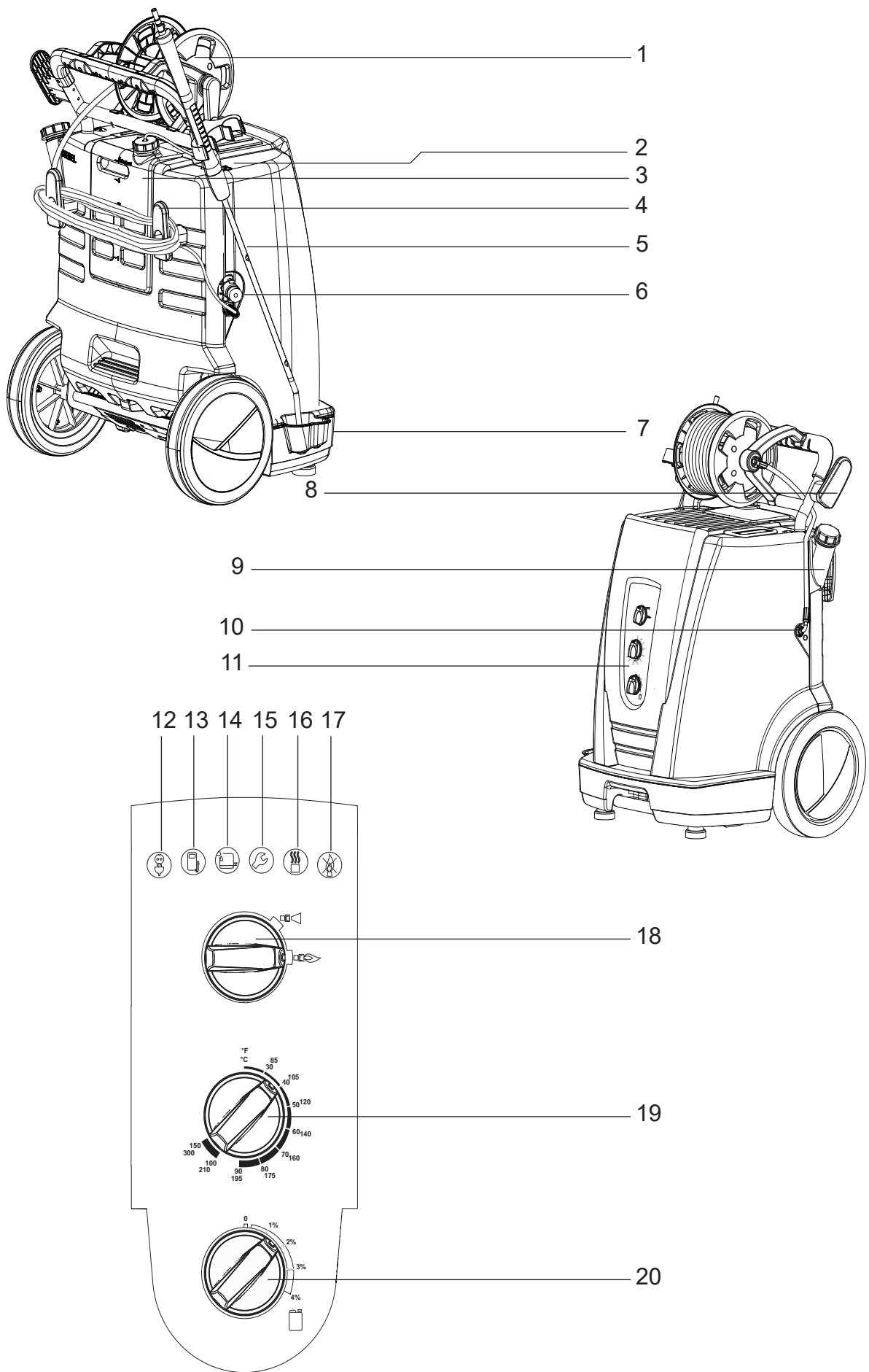

1	Safety instructions	5
2	Description	6
2.1	Purpose	6
2.2	Operating elements	6
3	Before starting the cleaner	7
3.1	Setting up the cleaner	7
3.2	Before use	7
3.3	Fill up detergent tank ¹⁾	7
3.4	Fill up fuel tank	8
3.5	Connecting the high pressure hose.....	8
3.6	Connecting the water supply	8
3.7	Electrical connection	9
3.8	Antifreeze - before first use	9
4	Control / Operation	10
4.1	Switching on the cleaner	10
4.2	Connections	10
4.3	Pressure regulation (Ergo Vario Press Gun) ¹⁾	11
4.4	Using cleaning agents	11
5	Applications and methods	12
5.1	Techniques	12
5.2	Some typical cleaning tasks	12
6	After using the cleaner	14
6.1	Switching off the cleaner and disconnecting supply lines	14
6.2	Rolling up the electrical lead and storing accessories.....	14
6.3	MH 1C Storing the cleaner (below 0°C)	14
6.4	MH 2C/MH 2M Storing the cleaner (below 0°C)	15
6.5	Transporting the cleaner	15
7	Maintenance	16
7.1	Maintenance plan	16
7.2	Maintenance work	16
8	Troubleshooting	17
8.1	Indications on Display	17
8.2	Other Faults.....	18
9	Further information	19
9.1	Recycling the cleaner	19
9.2	Guarantee	19
9.3	EU Declaration of Conformity	19
	Specifications	407

Symbols used to mark instructions



Safety instructions in these operating instructions which must be observed to prevent risks to persons are marked with this danger symbol.



This indicates tips and instructions to simplify work and to ensure safe operation.

EN



Before using the high-pressure cleaner, be sure to also read the enclosed operating instructions and keep them within reach at all times.



This symbol is used to mark safety instructions that must be observed to prevent damage to the machine and its performance.

1 Safety instructions

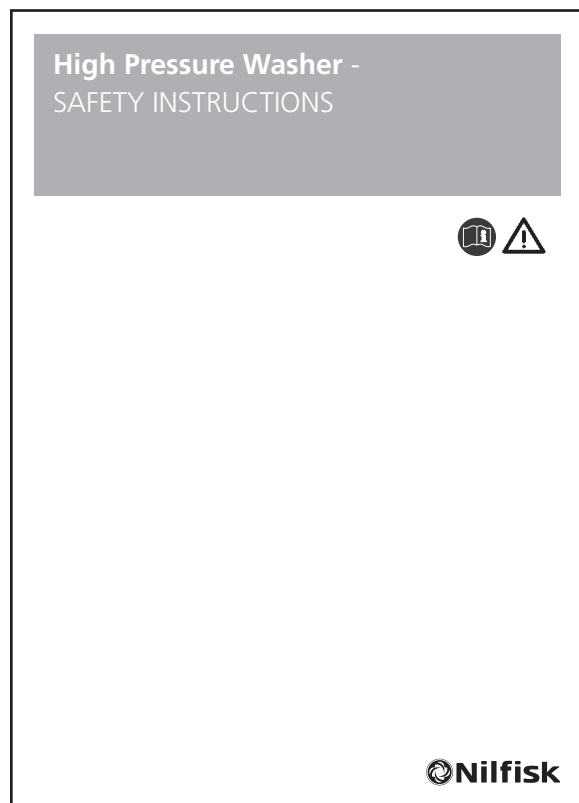

2 Description

2.1 Purpose

This high-pressure cleaner has been designed for professional use. It can be used for cleaning agricultural and construction equipment, stables, vehicles, rusty surfaces, etc.

The cleaner has not been approved for cleaning surfaces which comes into contact with food.

Chapter 5 describes the use of the high-pressure cleaner for various cleaning jobs.

Always use the cleaner as described in these operating instructions. Any other use may damage the cleaner or the surface to be cleaned or may result in severe injury to persons.

MH 1C is for light professional use only.

2.2 Operating elements



See illustration at front of these operating instructions.

1. High pressure hose reel¹⁾
2. Top cover release
3. Cannister for detergent
4. Cable hook
5. Spray lance
6. Supply water connection
7. Spray lance storage
8. Hose hook
9. Tank filler for fuel
10. High pressure hose connection for machines without hose reel
11. Control panel
12. Power ON
13. Fuel low
14. Nilfisk AntiStone low¹⁾
15. Service interval due/expired
16. Boiler overheated
17. Flame sensor is sooted
18. Main switch
19. Temperature controller
20. Detergent metering knob¹⁾

3 Before starting the cleaner



3.1 Setting up the cleaner

Every fuel-burning appliance, such as pressure washers, depends upon a proper mix of fuel and air (by weight) for proper combustion. Therefore some adjustment of the air regulation to the burner may be necessary to take account of altitude and the resulting air pressure. This is true whether your fuel is Kerosene or Diesel.

Your Nilfisk hot water pressure washer was thoroughly tested and adjusted for optimum per-

formance before it left our factory. The factory is located at approximately 140m (450 ft) above sea level, and the combustion settings are optimal for that elevation.

If your location is higher than 1200m (3900 ft) above sea level, your burner may require re-adjustment for proper performance and best fuel economy. Contact your Dealer or Nilfisk for assistance.

3.2 Before use

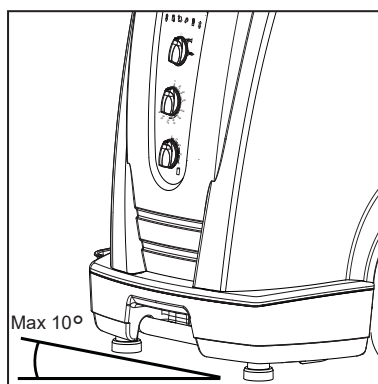

1. Before using the cleaner for the first time, check it carefully to detect any faults or damage.
2. Run the machine only when it is in perfect condition.
3. The slope on which the high pressure cleaner is placed must not exceed more than 10° in any direction.

3.3 Fill up detergent tank¹⁾

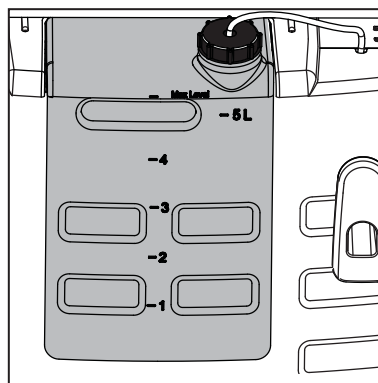

1. Fill up detergent tank with prediluted detergent.

¹⁾ Options / model variants

3.4 Fill up fuel tank

NOTE!

At temperatures below 8° C, the fuel oil begins to solidify (paraffin precipitation). This can lead to difficulties in starting the burner. Before the winter period either add a solidification point / flow improver (available from the fuel oil trade) to the fuel or use winter diesel fuel.

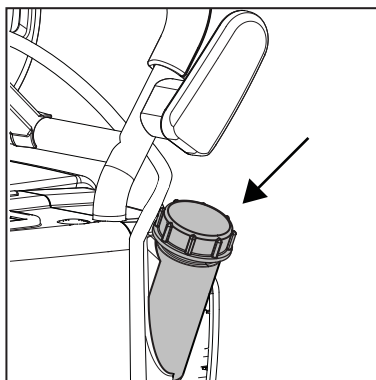

With the machine cold:

Fill fuel tank from a clean container with a fresh fuel, heating oil, DIN 51603-1 (without bio diesel) or Diesel EN 590 (Diesel with a bio diesel content up to 7%).

Diesel according to EN 590 (up to 7% bio diesel) can be used with the following restrictions: Maximum storage time in high pressure cleaner diesel tank: 1 month.

Diesel stored externally for more than 6 months is not allowed to be filled into Nilfisk high pressure cleaners.

Diesel EN 590 is not recommended for use in HPW's at an ambient temperature below 0°C. Diesel EN 590 from an open container must not be used.

The fuel must be free from contamination.

Be careful not to damage the fuel tank filter to avoid dirt entering in the tank

3.5 Connecting the high pressure hose

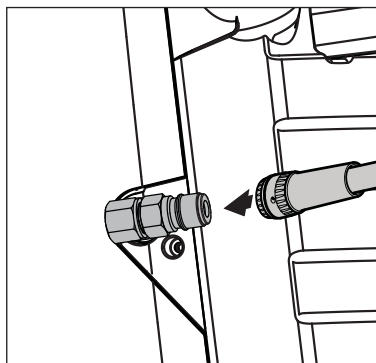

1. Put the quick connector of the high pressure hose onto the nipple on the cleaner.¹⁾

3.6 Connecting the water supply



In the case of poor water quality (sand, etc.), we recommend that a fine water filter is fitted in the water inlet.

We recommend the use of a textile-reinforced water hose with a nominal diameter of min. 3/4" (19 mm).

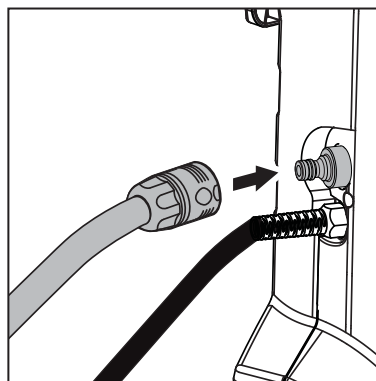

1. Rinse the water supply hose briefly in order to prevent sand and other dirt particles entering into the machine.
2. Connect water supply hose to the machine.
3. Open water tap.

3.7 Electrical connection



CAUTION!

When using cable reels:

1. Due to the risk of overheating and fire, always unwind the power supply cord fully.

The cleaner may only be connected to a correctly installed electrical installation.

1. Observe safety instructions in chapter 1.
2. Put the plug into the electrical socket.



3.8 Antifreeze - before first use

The machine is protected with anti-freeze from the factory.

Catch the liquid discharging at first (approx. 5 l) for re-use in a container.

4 Control / Operation

4.1 Switching on the cleaner



NOTE!

Always remove any dirt from the nipple before connecting the spray lance to the spray gun.

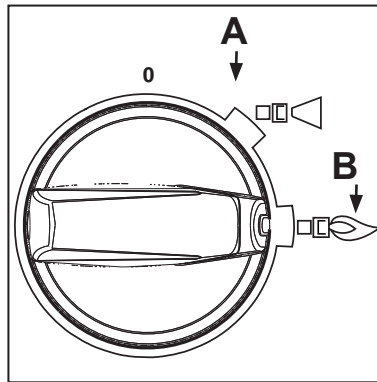

1. Move the main switch into position 'Cold Water' (A)

The control electronics system performs a self-test, all the LEDs light up once.

The motor starts

 lights up.

2. Ventilate the machine for air by activating the spray gun
3. When the water flow is even, continue with the following steps

4.2 Connections

4.2.1 Connecting the spray lance to the spray gun

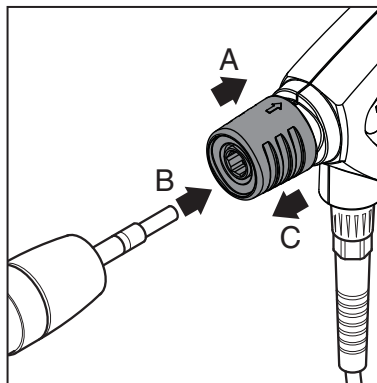

1. Pull the blue quick-release grip (A) of the spray gun backwards.
2. Insert the nipple of the spray lance (B) into the quick-release connection and release it.
3. Pull the spray lance (or other accessory) forwards to check that it is securely attached to the spray gun.

4.2.2 Hot water operation (up to 100°C)

IMPORTANT!

In the case of appliances with a hose reel:

In hot water mode, unwind the high-pressure hose fully from the hose reel, as otherwise the hose reel may become warped due to the effects of the heat.

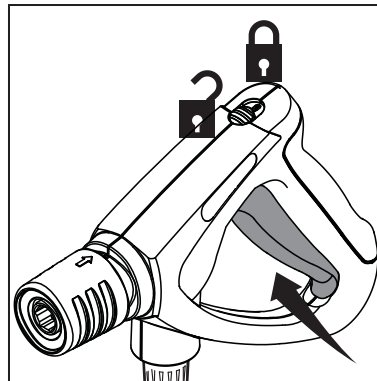

1. Move main switch into the position 'Hot Water' (B) and select the required temperature on the temperature control
2. Unlock the spray gun and actuate it

The burner switches on.

In case of interruptions in work: Also be sure to insert the safety catch even during short interruptions in work (see Fig. in section 6.1)

4.2.3 Steam operation (over 100°C)¹⁾



Beware of hot water and steam discharge up to 150°C when operating in steam stage.

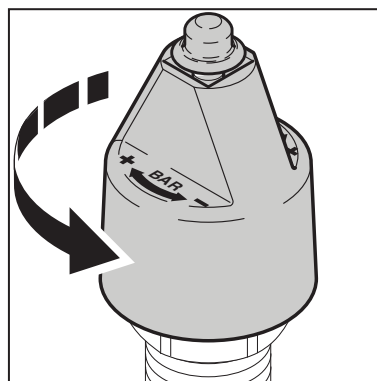

1. Replace the standard nozzle with the steam spray nozzle (See catalogue for accessories).
2. Open cover.
3. Turn the twist grip on the safety control block completely to the left (anticlockwise direction).
4. Turn the main switch into position 'Hot Water'.
5. Select temperature (over 100°C).

4.3 Pressure regulation (Ergo Vario Press Gun)¹⁾

For safety reasons, never tie back or wedge open the trigger of the spray gun in open position during operation. The trigger must be free to close when released, thus interrupting the flow of the water.

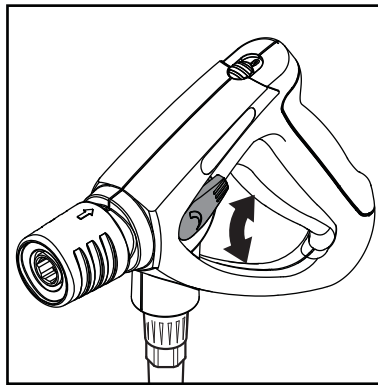

1. Operate the Vario trigger in order to vary the water flow and thereby the pressure.
2. Push the trigger forwards to obtain full pressure and flow.



4.4 Using cleaning agents

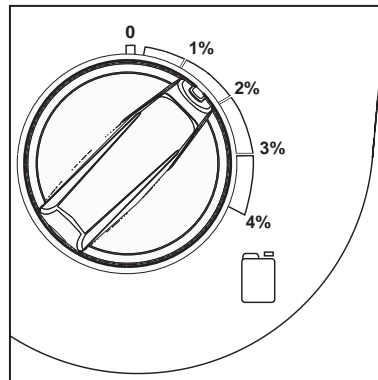
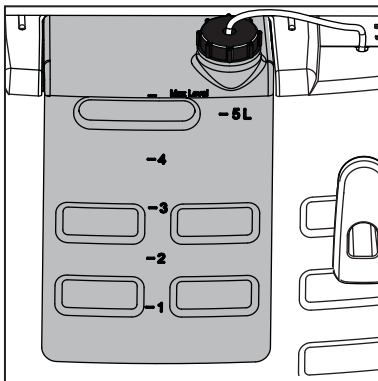

CAUTION!

Never allow cleaning agent to dry on the surface to be cleaned. The surface may be damaged.

For special applications (e.g. disinfection) the exact detergent concentration has to be determined by measuring cup.

MH 1C

Cleaning agent can be drawn in via the injector installed as standard only in low-pressure mode:

1. Dilute cleaning agent according to the manufacturer's instructions.
2. Turn cap of the FlexoPowerPlus nozzle head towards „CHEM“ up to the stop.
3. The intaken volume of cleaning agent can be regulated by turning the metering valve.
4. Main switch
Turn the switch to position "I".
5. Operate the spray gun.

MH 2C/MH 2M

1. Set the desired concentration of cleansing agent at the cleansing agent dosing facility.
2. Spray the object to be cleaned.
3. Allow the cleaning agent to work, depending on the degree of soiling. Then rinse off with the high pressure spray jet.

¹⁾ Options / model variants

5 Applications and methods

5.1 Techniques

Efficient high pressure cleaning is achieved by following a few guidelines, combined with your own personal experience of specific cleaning tasks. Accessories and detergents, when correctly chosen, can increase the efficiency of your pressure washer. Here is some basic information about cleaning.

5.1.1 Soaking

Encrusted or thick layers of dirt can be loosened or softened by a period of soaking. An ideal method within agriculture – for example, within pig sties. The soaking method can be achieved by use of foam or simple alkaline detergent. Let the product lie on the dirty surfaces for around 15 minutes before pressure washing. The result will be a much quicker high pressure cleaning process.

5.1.2 Detergent and Foam

Foam or detergent should be applied onto dry surfaces (not in direct sun light) so that the chemical product is in direct contact with the dirt. Detergents are applied from bottom to top, for example on a car bodywork, in order to avoid “super clean” areas, where the detergent collects in higher concentration and streams downwards. Let the detergent work for several minutes before rinsing but never let it dry on the surface being cleaned.

5.1.3 Temperature

Detergents are more effective at higher temperatures. Greases, oils and fats can be broken down more easily at higher temperatures also. Proteins can be cleaned at temperatures of around 60°C. Oils, traffic film around 70°C, and grease can be cleaned at 80°C - 90° C.

5.1.4 Mechanical Effect

In order to break down tough layers of dirt, additional mechanical effect may be required. Special lances and rotary or wash brushes offer this supplementary effect that cuts through dirt.

5.1.5 High Water Flow or High Pressure

High pressure is not always the best solution and high pressure may damage surfaces. The cleaning effect also depends upon water flow. Pressure levels of around 100 bar may be sufficient for vehicle cleaning (in association with hot water). Higher flow levels give the possibility to rinse and flush away large amounts of dirt easily.

5.2 Some typical cleaning tasks

5.2.1 Agriculture

Task	Accessories	Method
Stables Pig Pens, Sties Cleaning of walls, floors and equipment Disinfectant	Chemical Foam Injectors Foam lance Powerspeed lance Floor Cleaner Detergents Universal Alkafoam Disinfectant DES 3000	<ol style="list-style-type: none"> 1. Soaking – apply foam to all surfaces (bottom to top) and wait for approx. 15 minutes. 2. Remove the dirt from surfaces with the high pressure lance or chosen accessory. Again, clean from bottom to top on vertical surfaces. 3. To flush away large quantities of dirt, change to low pressure mode and use the higher flow to push away the dirt. 4. Use recommended disinfectant products and methods to ensure hygiene. Apply DES 3000 disinfectant once the surfaces are perfectly clean.
Machinery Tractors ploughs etc.	Detergent injection Powerspeed lances Curved lances and underchassis washers Brushes	<ol style="list-style-type: none"> 1. Apply detergent to vehicle or equipment surfaces in order to soften up dirt and grime. Apply from bottom to top. 2. Proceed with cleaning using the high pressure lance. Clean again from bottom to top. Use accessories to clean in difficult to reach places. 3. Clean fragile areas such as motors, rubber at lower pressure levels to avoid damage.

5.2.2 Vehicle

Task	Accessories	Method
Vehicle bodywork	Standard lance Detergent injection Curved lances and underchassis washers brushes Detergents Aktive Shampoo Aktive Foam Sapphire Super Plus Aktive Wax Allosil RimTop	<ol style="list-style-type: none"> 1. Apply detergent to vehicle or equipment surfaces in order to soften up dirt and grime. Apply from bottom to top. In cases of particularly dirty vehicles, pre-spray with a product such as Allosil in order to remove traces of insects etc, then rinse at low pressure and apply normal car cleaning detergent. Let detergents settle for 5 minutes before cleaning off. Metallic surfaces can be cleaned using RimTop. 2. Proceed with cleaning using the high pressure lance. Clean again from bottom to top. Use accessories to clean in difficult to reach places. Use brushes in order to add a mechanical cleaning effect. Short lances can help for cleaning of motors and wheel arches. Curved lances or undercarriage washers can be valuable for the cleaning of car underchassis and wheel arches. 3. Clean fragile areas such as motors, rubber at lower pressure levels to avoid damage. 4. Apply a liquid wax using the pressure washer in order to protect the bodywork from pollution.

5.2.3 Buildings and Equipment

Task	Accessories	Method
General surfaces Metallic equipment	Foam injectors Standard lance Curved lances Tank cleaning head Detergents Intensive J25 Multi Combi Aktive Alkafoam Disinfectant DES 3000	<ol style="list-style-type: none"> 1. Apply thick foam over the surfaces to be cleaned. Apply on dry surfaces. Apply from top to bottom on vertical surfaces. Let the foam act for up to 30 minutes for the optimal effect. 2. Proceed with cleaning using the high pressure lance. Use applicable accessories. Use high pressure to dislodge large amounts of incrustated dirt or grime. Use lower pressure and high water volume in order to rapidly flush away loose dirt and rinse surfaces. 3. Apply DES 3000 disinfectant once the surfaces are perfectly clean. <p>Areas covered by amounts of loose dirt, such as animal remains in slaughterhouses, can be cleaned by using high water flow to flush away the dirt to evacuation pits or drains.</p> <p>Tank cleaning heads can be used to clean barrels, vats, mixing tanks etc. Cleaning heads may be hydraulically or electrically powered and give the possibility for automatic cleaning without a constant user.</p>
Rusted or damages surfaces prior to treatment	Wet Sandblasting equipment	<ol style="list-style-type: none"> 1. Connect the sandblasting lance to the pressure washer and place the suction tube in the sand. 2. Always wear protective equipment during sandblasting. 3. Spray the surfaces to be treated with the mix of water and sand. Rust, paint etc will be stripped off.

These are merely several examples of cleaning tasks that can be solved by a pressure washer in association with accessories and detergents. Each cleaning task is different. Please consult your local dealer or Nilfisk representative in order to discuss the best solution for your own cleaning tasks.

6 After using the cleaner

6.1 Switching off the cleaner and disconnecting supply lines

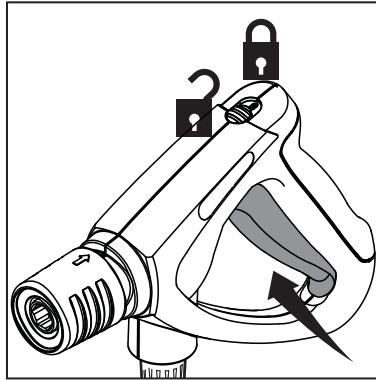

1. Close water tap.
2. Activate spray gun without lance in order to empty all residual water in the system.
3. Turn the main switch to position „OFF“.
4. Pull out the plug from the electrical socket.
5. Squeeze the spray gun handle until the cleaner is depressurised.
6. Lock the safety catch on the spray gun.
7. Remove the water hose from the cleaner.

6.2 Rolling up the electrical lead and storing accessories

To prevent accidents, always carefully roll up the electrical lead and the high pressure hose.

Place the spray lance into the storage position.

6.3 MH 1C Storing the cleaner (below 0°C)

Store the cleaner in a dry room without danger of frost or protect as below:

1. Remove the water inlet hose from the water supply.
2. Place the water inlet hose in a bucket containing an antifreeze.
3. Remove the spray lance.
4. Switch on the cleaner with the main switch in position "Cold Water".
5. Operate the spray gun.
6. During suction operate the spray gun two or three times.
7. The machine is protected against frost when antifreeze solution emerges from the spray gun.
8. Lock the safety catch on the spray gun.
9. Remove the water inlet hose from the bucket
10. Switch off the cleaner and store it in upright position.
11. When the machine is put into service again, the antifreeze solution must be collected and stored for future or proper disposal.

6.4 MH 2C/MH 2M Storing the cleaner (below 0°C)

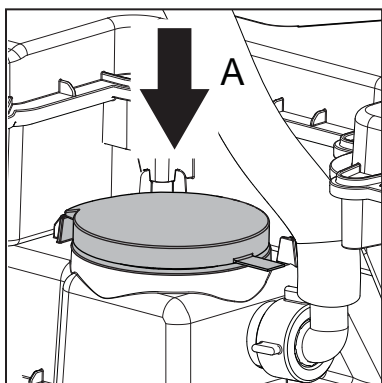

Store the cleaner in a dry room without danger of frost or protect as below:

1. Remove the water inlet hose from the cleaner.
2. Remove the spray lance.
3. Switch on the cleaner with the main switch in position "Cold Water".
4. Operate the spray gun.
5. Open the cover (A)
6. Gradually pour antifreeze (approx. 5 litres) into the water tank.
7. During suction operate the spray gun two or three times.
8. The machine is protected

against frost when antifreeze solution emerges from the spray gun.

9. Lock the safety catch on the spray gun.
10. Close the cover
11. Switch off the cleaner.
12. To avoid any risks, store the cleaner temporarily in a heated room in upright position.
13. When the machine is put into service again, the antifreeze solution can be collected and stored for future use.

EN

6.5 Transporting the cleaner

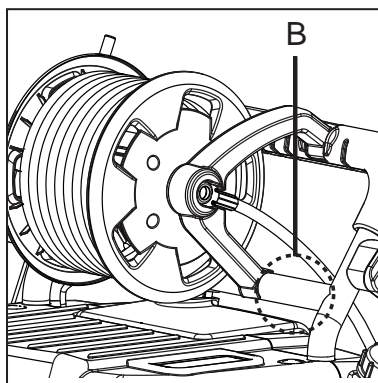
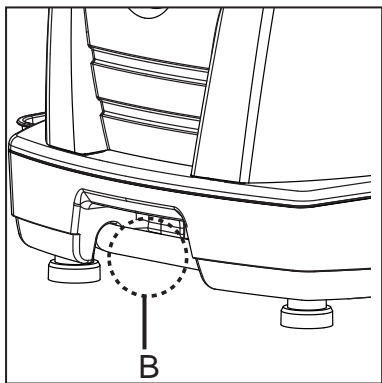

The machine can be in either upright position or tilted position during transportation.

Use the fixing points (B) when securing with belts.



Notice the risk of leaking water by sudden heavy movements during transportation.

EN 7 Maintenance

7.1 Maintenance plan

Maintain water filters and fuel filters as required.

7.2 Maintenance work

7.2.1 Water filters

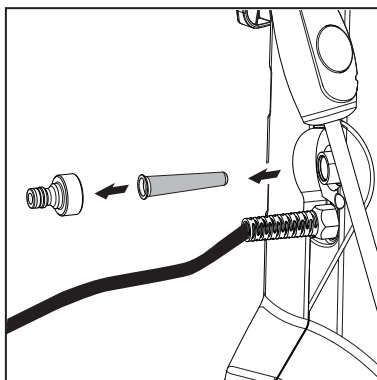

A water filter is fitted on the water inlet to prevent large particles of dirt from entering into the pump.

1. Unscrew quick coupling with tool.
2. Remove filter and clean it.
3. Remount the filter and quick coupling

7.2.2 Maintenance of fuel filter

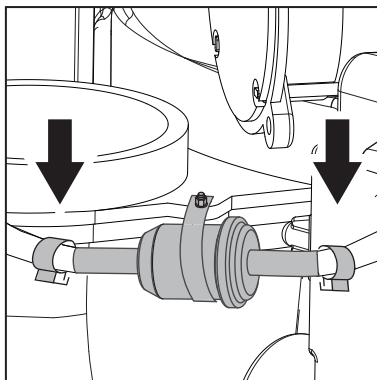

1. Open hose clips
2. Replace fuel filter
3. Close hose clips
4. Dispose the cleaning solution/damaged filter in accordance with the disposal regulations

7.2.3 Emptying the fuel tank

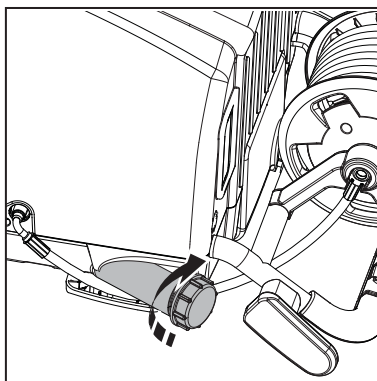

1. Unscrew the cap
2. Remove the strain
3. Tilt the machine to a horizontal position
4. Let the fuel pour into an empty container

7.2.4 Flame sensor¹⁾

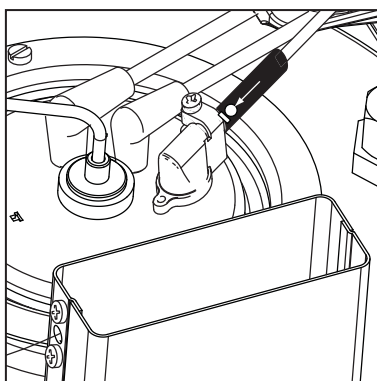

1. Dismount the sensor and clean with a soft cloth.
2. Ensure that the sensor is correctly seated when installing again - the symbols must face upwards.













8 Troubleshooting

8.1 Indications on Display

Indication lights						Cause	Remedy
						<ul style="list-style-type: none"> > The light is constant <ul style="list-style-type: none"> - The appliance is ready for operation > Flashing light <ul style="list-style-type: none"> - Flow sensor fault - Water tap closed or water shortage - Detergent tank empty - Pressure regulation on the safety control blocks or the VarioPress¹⁾ lance is set to low water volume - Machine scaled - Spray gun is leaking - High pressure hose, coupling or line system is leaking - Motor is overheated³⁾ 	<ul style="list-style-type: none"> > Refuel detergent or set SDR value to "0" <p>Turn main switch to position "OFF" - let the machine cool down Remove/disconnect extension cable</p>
						<ul style="list-style-type: none"> > Constant light <ul style="list-style-type: none"> - Low fuel level 	<ul style="list-style-type: none"> > Top up fuel > Cold water operation is possible
						<ul style="list-style-type: none"> > Flashing light <ul style="list-style-type: none"> - Low Nilfisk AntiStone level¹⁾ 	<ul style="list-style-type: none"> > Top up Nilfisk AntiStone
						<ul style="list-style-type: none"> > Constant light <ul style="list-style-type: none"> - Service interval has expired > Flashing light <ul style="list-style-type: none"> - Service interval due in 20 hours - Microprocessor error 	<ul style="list-style-type: none"> > Contact Nilfisk Service > Contact Nilfisk Service > Machine shutdown
						<ul style="list-style-type: none"> > Constant light <ul style="list-style-type: none"> - Boiler overheated. Exhaust sensor (EXT-H) has cut off fuel supply - Insufficient water flow - Machine scaled - Boiler not serviced 	<ul style="list-style-type: none"> > Machine shuts down. Cold water operation is possible. > Check water supply > Contact Nilfisk Service
						<ul style="list-style-type: none"> > Constant light <ul style="list-style-type: none"> - Flame sensor (B7) is sooted - Ignition or fuel system failure 	<ul style="list-style-type: none"> > Clean flame sensor (B7) (see chapter 7.2.4) > Contact Nilfisk Service > Cold water operation is possible

¹⁾ Options / model variants

³⁾ For MH 1C only. For MH 2C/MH 2M overheating warning see next page.

Indication lights						Cause	Remedy
						> No indication and main switch is on - Motor is overheated - Main fuse has blown	<ul style="list-style-type: none"> • Turn main switch to position "OFF" - let the machine cool down Remove/disconnect extension cable Possible phase failure on 3 phase variants¹⁾: have electrical connection checked Contact Nilfisk Service • Check main fuse
						> Flashing light - Faulty temperature sensor (B1)	<ul style="list-style-type: none"> • Cold water operation is possible • Check wire to temperature sensor (B1) • Contact Nilfisk Service
						> Flashing light - Flow sensor fault	<ul style="list-style-type: none"> • Cold water operation is possible • Contact Nilfisk Service
						> Flashing light - Overheat error has occurred	<ul style="list-style-type: none"> • Cold water operation is possible • Contact Nilfisk Service
						> Visual test of lamps - When switching on, all LEDs light up for approximately 1 second	

8.2 Other Faults

Fault	Cause	Remedy
 not ON	> Plug not connected to the electrical plug socket	<ul style="list-style-type: none"> • Put the plug into the electrical socket.
		<ul style="list-style-type: none"> • Check fuse
Pressure too low	> High pressure nozzle worn out	<ul style="list-style-type: none"> • Replace nozzle
	> Pressure regulation set to low pressure or VarioPress-lance ¹⁾ set to low water volume ¹⁾ .	<ul style="list-style-type: none"> • Turn the twist grip on safety control block clockwise (+) or set VarioPress-lance¹⁾ to higher water volume (see chapter 4.4)
Machine is running with pulsating pressure and makes knocking noise	> Pump has drawn in air as the detergent tank is empty	<ul style="list-style-type: none"> • Close detergent valve. Remove lance from gun. Operate spray gun and let machine run until air in pump is gone and the machine is running normally again.
No detergent drawn in	> Detergent tank empty	<ul style="list-style-type: none"> • Top up detergent tank
	> Dirt in detergent tank	<ul style="list-style-type: none"> • Clean detergent tank
	> Suction valve at cleaning agent inlet soiled	<ul style="list-style-type: none"> • Remove suction valve and clean or replace
Burner soots up	> fuel contamination	<ul style="list-style-type: none"> • Contact Nilfisk Service
	> Burner sooted or adjustment incorrect	

9 Further information



9.1 Recycling the cleaner



If the cleaner is discarded, make it unusable immediately

1. Unplug the cleaner and cut the power cord.

The cleaner contains valuable materials that should be recycled. Therefore, make use of your local waste disposal site. Contact your local authorities or your nearest dealer for further information.

9.2 Guarantee

Our general conditions of business are applicable with regard to the guarantee. Subject to change as a result of technical advances. The guarantee is invalidated if

the machine is not operated in accordance with these instructions or otherwise abused. The guarantee is invalidated if the machine is not serviced as described.

9.3 EU Declaration of Conformity

We,
Nilfisk A/S
Kornmarksvej 1
DK-2605 Broendby
DENMARK

Hereby declare that the
Products: HPW - Professional - Mobile - EI
Description: 230V/50Hz, 400V/3~/50Hz, IPX5
Type: MH 1C*, MH 2C*, MH 2M*



















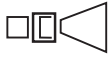
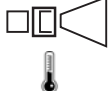

Are in compliance with the following standards:
EN 60335-1:2012+A11:2014
EN 60335-2-79:2012
EN 55014-1:2006+A1:2009+A2:2011
EN 55014-2:2015
EN 61000-3-2:2014
EN 61000-3-11:2000

Following the provisions of:
2006/42/EC
2014/30/EU
2000/14/EC – Conformity assessment procedure according to Annex V.
- Measured sound power level: 77-81,6 dB(A)
- Guaranteed sound power level: 89,5-93,5 dB(A)

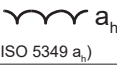

















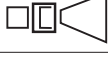



Hadsund, 02-09-2016

Anton Sørensen
Senior Vice President, Global R&D

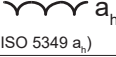

















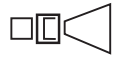
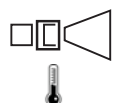

Specifications

			MH 1C-110/600	MH 1C-110/600	MH 2C-90/670 X	MH 2C-145/600
1			EU	GB	GB	EU
2		V/ph/Hz	230/1/ 50	230/1/ 50	230/1/ 50	230/1/ 50
3		A	C 16	C 13	C 13	C 16
4		kW кВт	2,8	2,8	2,9	3,4
5		A	12	12	12,4	14,5
6		bar (MPa) Бар (МПа) 巴 (兆帕)	110	110	90	145
7		l/min л/мин 升/分钟	9,0	9,0	10,7	8,8
8		bar (MPa) Бар (МПа) 巴 (兆帕)	165	165	135	218
9		l/min	10,0	10,0	11,2	10,0
10			NT 0400	NT 0400	NT 0530	NT 0340
11		°C (°F)	80/-	80/-	90/150	90/150
12		°C (°F)	40			
13		bar (MPa) Бар (МПа) 巴 (兆帕)	10			
14		mm 毫米	607/688/1000	607/688/1000	607/688/1071	607/688/1000
15		kg кг	94	94	112	110
16	 $K_{PA} = 3 \text{ dB}$	dB(A) дБ(А)	74	74	76,6	77
17	 $K_{WA} = 3 \text{ dB}$	dB(A) дБ(А)	88,0	88,0	88,2	89,8
18	 (ISO 5349 a_h)	m/s ² 米/秒 ²	<1,5; +/-1	<1,5; +/-1	<1,5; +/-1	<1,5; +/-1
19		N	17,6	17,6	18,2	20,8
20		L л 升	0,10 Agip Rotra	0,10 Agip Rotra	0,20 Agip Rotra	0,20 Agip Rotra
21		kW кВт	36	36	44	36
22		L/л/升	17			
23		L/л/升	A: 5 (int.)	A: 5 (int.)	A: 5 (int.)	A: 5 (int.)



















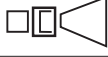
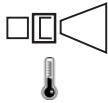

Specifications

			MH 2C-145/600 X	MH 2M-140/600	MH 2M-140/600 X	MH 2M-155/660
1			EU	EU	EU	EU
2		V/ph/Hz	230/1/ 50	230/1/ 50	230/1/ 50	400/3/50
3		A	C 16	C 16	C 16	C 16
4		kW кВт	3,4	3,4	3,4	3,8
5		A	14,5	14,5	14,5	8
6		bar (MPa) Бар (МПа) 巴 (兆帕)	145	140	140	155
7		l/min л/мин 升/分钟	8,8	9,3	9,3	10,0
8		bar (MPa) Бар (МПа) 巴 (兆帕)	218	210	210	233
9		l/min	10,0	10,0	10,0	11,0
10			NT 0340	NT 0350	NT 0350	NT 0350
11		°C (°F)	90/150	80/-	80/-	80/-
12		°C (°F)	40			
13		bar (MPa) Бар (МПа) 巴 (兆帕)	10			
14		mm 毫米	607/688/1071	607/688/1000	607/688/1071	607/688/1000
15		kg кг	112	97	99	97
16	 K _{PA} = 3 dB	dB(A) дБ(А)	77	74,2	74,2	74,3
17	 K _{WA} = 3 dB	dB(A) дБ(А)	89,8	88,5	88,5	88,8
18	 (ISO 5349 a _h)	m/s ² 米/秒 ²	<1,5; +/-1	<1,5; +/-1	<1,5; +/-1	<1,5; +/-1
19		N	20,6	21,5	21,4	24,3
20		L л 升	0,20 Agip Rotra	0,23 Agip Rotra	0,23 Agip Rotra	0,23 Agip Rotra
21		kW кВт	36	36	36	44
22		L/л/升	17			
23		L/л/升	A: 5 (int.)	A: 5 (int.)	A: 5 (int.)	A: 5 (int.)



















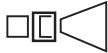
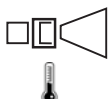

Specifications

			MH 2M-155/660 X	MH 2C-170/690	MH 2C-170/690 X	MH 2C-170/690 X
1			EU	EU	EU	NO
2		V/ph/Hz	400/3/50	400/3/50	400/3/50	230/400/3/50
3		A	C 16	C 16	C 16	C 16
4		kW кВт	3,8	4,1	4,1	4,1
5		A	8	8	8	14,3/8
6		bar (MPa) Бар (МПа) 巴 (兆帕)	155	170	170	170
7		l/min л/мин 升/分钟	10,0	10,5	10,5	10,5
8		bar (MPa) Бар (МПа) 巴 (兆帕)	233	250	250	250
9		l/min	11,0	11,5	11,5	11,5
10			NT 0350	NT 0370	NT 0370	NT 0370
11		°C (°F)	80/-	90/150	90/150	90/150
12		°C (°F)	40			
13		bar (MPa) Бар (МПа) 巴 (兆帕)	10			
14		mm 毫米	607/688/1071	607/688/1000	607/688/1071	607/688/1071
15		kg кг	99	110	112	112
16	 $K_{PA} = 3 \text{ dB}$	dB(A) дБ(А)	74,3	80	80	80
17	 $K_{WA} = 3 \text{ dB}$	dB(A) дБ(А)	88,8	92,5	92,5	92,5
18	 (ISO 5349 a _h)	m/s ² 米/秒 ²	<1,5; +/-1	<1,5; +/-1	<1,5; +/-1	<1,5; +/-1
19		N	24,0	27,1	26,3	26,3
20		L л 升	0,23 Agip Rotra	0,20 Agip Rotra	0,20 Agip Rotra	0,20 Agip Rotra
21		kW кВт	44	44	44	44
22		L/л/升	17			
23		L/л/升	A: 5 (int.)	A: 5 (int.)	A: 5 (int.)	A: 5 (int.)

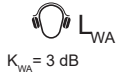
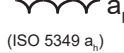

Specifications





			MH 2C-190/780	MH 2C-190/780 X	MH 2C-125/600	MH 2C-145/600
1			EU	EU	KR	AU
2		V/ph/Hz	400/3/50	400/3/50	220/1/60	240/1/50
3		A	C 16	C 16	C 16	C 15
4		kW кВт	5,1	5,1	3,2	3,4
5		A	9	9	14,3	14,5
6		bar (MPa) Бар (МПа) 巴 (兆帕)	190	190	125	145
7		l/min л/мин 升/分钟	12,2	12,2	9,0	8,8
8		bar (MPa) Бар (МПа) 巴 (兆帕)	250	250	188	218
9		l/min	13,0	13,0	10,0	10,0
10			NT 0400	NT 0400	NT 0350	NT 0340
11		°C (°F)	90/150	90/150	90/150	90/150
12		°C (°F)	40			
13		bar (MPa) Бар (МПа) 巴 (兆帕)	10			
14		mm 毫米	607/688/1000	607/688/1071	607/688/1000	607/688/1000
15		kg кг	110	112	110	110
16	 K _{PA} = 3 dB	dB(A) дБ(А)	81,6	81,6	77	77
17	 K _{WA} = 3 dB	dB(A) дБ(А)	93,5	93,5	89,50	89,8
18	 (ISO 5349 a _h)	m/s ² 米/秒 ²	<3,5; +/-1	<3,5; +/-1	<1,5; +/-1	<1,5; +/-1
19		N	32,9	32,0	19,6	20,8
20		L л 升	0,20 Agip Rotra	0,20 Agip Rotra	0,20 Agip Rotra	0,20 Agip Rotra
21		kW кВт	50	50	36	36
22		L/л/升	17			
23		L/л/升	A: 5 (int.)	A: 5 (int.)	A: 5 (int.)	A: 5 (int.)



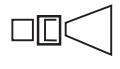
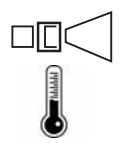



Specifications

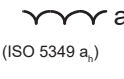

			MH 2C-100/450
1			AU
2		V/ph/Hz	240/1/50
3		A	C 10
4		kW кВт	2,2
5		A	9,6
6		bar (MPa) Бар (МПа) 巴 (兆帕)	100
7		l/min л/мин 升/分钟	6,7
8		bar (MPa) Бар (МПа) 巴 (兆帕)	150
9		l/min	7,5
10			25030
11		°C (°F)	90/150
12		°C (°F)	40
13		bar (MPa) Бар (МПа) 巴 (兆帕)	10
14		mm 毫米	607/688/1000
15		kg кг	110
16		dB(A) дБ(A)	77
17		dB(A) дБ(A)	89,5
18		m/s ² 米/秒 ²	<1,5; +/-1
19		N	13,0
20		L л 升	0,20 Agip Rotra
21		kW кВт	32
22		L/л/升	17
23		L/л/升	A: 5 (int.)

1			EN: Country variant. DE: Ländervarianten. FR: Selon le pays. NL: Nationale variant. IT: Variante per il Paese. NO: Variant i ulike land. SV: Landsvariant. DA: Landespecifik variant. FI: Maakohtainen vaihtelu. ES: Dependé del país. PT: Variante do país. EL: Έκδοση χώρας. TR: Ülkedeki model. SL: Jezikovna različica. HR: Ovisno o zemlji. SK: Vrsta ulja. CS: Varianta země. PL: Wersja dla kraju. HU: Országfüggő modellváltozatok. RO: Varianta țării. BG: Вариант за страната. RU: Региональное исполнение. ET: Riigi variant. LV: Valsts versija. LT: Šaliai skirtas variantas. JA: 国による相違。 ZH: 不同国家 KO: 국가별 모델. TH: แดกต่างกันไปตามประเทศ MS: Variasi negara.
2		V/ ph/ Hz	EN: Possible voltage. DE: Mögliche Spannung. FR: Tension autorisée. NL: Mogelijke spanning. IT: Possibile voltaggio. NO: Mulig spenning. SV: Möjlig spänning. DA: Spænding. FI: Mahdollinen jännite, V/vaiheluku/taajuus. ES: Tensión admitida. PT: Tensão possível. EL: Πιθανή τάση, V/ph/Frez. TR: Olası voltaj, V/Faz/Frekans. SL: Morebitna napetost. HR: Mogući napon. SK: Možné napätie. CS: Možné napětí. PL: Dopuszczalne napięcie, V/fazy/częst. HU: Tápészültség, V/fázis/frekv. RO: Tensiune posibilă, V/fază/Frecv. BG: Възможно напрежение. RU: Напряжение, В/ф./част. В/ф./Гц. ET: Võimalik pinge, V/faas/sagedus. LV: Iespējamais spriegums. LT: Galima įtampa V / F / Frez. JA: 電圧。 ZH: 可能电压 (V/ph/Frez) KO: 허용 전압, 볼트/상/헤르츠. TH: แรงดันไฟฟ้าที่สามารถใช้ได้ MS: Kemungkinan voltan.
3		A	EN: Fuse. DE: Sicherung. FR: Fusible. NL: Zekering. IT: Fusibile. NO: Sikring. SV: Säkring. DA: Sikring. FI: Sulake. ES: Fusible. PT: Fusível. EL: Ασφάλεια. TR: Sigorta. SL: Varovalka HR: Osigurač SK: Poistka CS: Pojistka. PL: Bezpiecznik. HU: Biztosíték. RO: Siguranță. BG: Предпазител RU: Предохранитель. ET: Kaitse. LV: Drošinātājs. LT: Saugiklis. JA: ヒューズ ZH: 保险丝 KO: 퓨즈. TH: ฟิวส์ MS: Fius
4		kW kBT	EN: Power rating. DE: Nennleistung. FR: Puissance nominale. NL: Nominiaal vermogen. IT: Corrente nominale. NO: Nominell effekt. SV: Märkeffekt. DA: Nominel effekt. FI: Tehontarve. ES: Potencia nominal. PT: Classificação de potência. EL: Ονομαστική ισχύς. TR: Elektrik değerleri. SL: Moč. HR: Oznaka napona. SK: Stanovenie výkonu. CS: Jmenovitý výkon. PL: Moc znamionowa. HU: Névleges teljesítmény. RO: Putere nominală. BG: Мощност. RU: Номинальная мощность кВт. ET: Vooluühik. LV: Nominālā jauda. LT: Galia. JA: 定格電力。 ZH: 额定功率 KO: 전원 등급. TH: อัตรากำลังไฟ MS: Penarafan kuasa.
5		A	EN: Current consumption. DE: Aktueller Verbrauch. FR: Consommation de courant. NL: Huidig verbruik. IT: Consumo di corrente. NO: Strømforbruk. SV: Strömförbrukning. DA: Strømforbrug. FI: Nykyinen kulutus. ES: Consumo actual. PT: Consumo de corrente. EL: Κατανάλωση ρεύματος. TR: Geçerli tüketim. SL: Poraba električne energije. HR: Potrošnja struje. SK: Aktuálna spotreba. CS: Odběr proudu. PL: Pobór prądu. HU: Áramfelvétel. RO: Consum de curent. BG: Консумация на електроенергия. RU: Текущий расход. ET: Praegune tarbimine. LV: Strāvas patēriņš. LT: Esamas suvartojimas. JA: 消費電流。 ZH: 电流消耗。 KO: 소비 전류. TH: กำลังไฟฟ้า MS: Penggunaan semasa.
6		bar (MPa) Бар (МПа) 巴 (兆帕)	EN: Working pressure. DE: Arbeitsdruck. FR: Pression de service. NL: Werkdruk. IT: Pressione di esercizio. NO: Arbeidstrykk. SV: Arbetstryck. DA: Arbejdsryk. FI: Työpaine. ES: Presión de trabajo. PT: Pressão de trabalho. EL: Πίεση λειτουργίας. TR: Çalışma basıncı. SL: Delovni tlak. HR: Radni tlak. SK: Pracovní tlak. CS: Provozní tlak. PL: Ciśnienie robocze. HU: Üzemnyomás. RO: Presiune de lucru. BG: Работно налягане. RU: Рабочее давление. ET: Töösurve. LV: Darba spiediens. LT: Darbinis slėgis. JA: 動作圧力。 ZH: 工作压力 KO: 작업 압력. TH: แรงดันขณะใช้งาน MS: Tekanan kerja

7		l/min л/МИН 升/分钟	EN: Water flow. DE: Wasserdurchsatz. FR: Débit d'eau. NL: Waterdoorstroming. IT: Flusso dell'acqua. NO: Vanntilførsel. SV: Vattenflöde. DA: Vandmængde. FI: Vedenvirtaus. ES: Flujo de agua. PT: Fluxo de água. EL: Ποή νερού. TR: Su akışı. SL: Pretok vode. HR: Regulacija protoka vode. SK: Prietok vody. CS: Průtok vody. PL: Przepływ wody. HU: Vízátfolyás. RO: Debit apă. BG: Воден поток. RU: Расход воды. ET: Veevool. LV: Ūdens plūsma. LT: Vandens srautas. JA: 流水 ZH: 水流量 KO: 급수량 TH: การไหลของน้ำ MS: Aliran air.
8		bar (MPa) Бар (МПа) 巴 (兆帕)	EN: Max. water pressure. DE: Max Wasserdruck. FR: Pression d'eau maximale. NL: Max. waterdruk. IT: Max. pressione dell'acqua. NO: Maks. vanntrykk. SV: Max vattentryck. DA: Max. vandtryk. FI: Suurin vedenpaine. ES: Presión máxima de entrada del agua. PT: Pressão máxima de água. EL: Μέγ. πίεση νερού. TR: Maks. su basıncı. SL: Najv. vodni tlak. HR: Maksimalni tlak vode. SK: Maximálny tlak vody. CS: Max. tlak vody. PL: Maks. ciśnienie wody. HU: Max. víznyomás. RO: Presiune max. apă. BG: Макс. налягане на водата. RU: Макс. давление воды. ET: Max veesurve. LV: Maks. ūdens spiediens. LT: Maks. vandens slėgis. JA: 最高水圧 ZH: 最大水压 KO: 최대 수압 TH: ความดันน้ำสูงสุด MS: Tekanan air maksimum.
9		l/min л/МИН 升/分钟	EN: Water flow DE: Wasserdurchsatz. FR: Débit d'eau. NL: Waterdoorstroming. IT: Flusso dell'acqua. NO: Vanntilførsel. SV: Vattenflöde. DA: Vandmængde. FI: Vedevirtaus. ES: Flujo de agua. PT: Fluxo de água. EL: Ποή νερού. TR: Su akışı. SL: Pretok vode. HR: Protok vode. SK: Prietok vody. CS: Průtok vody. PL: Przepływ wody. HU: Vízátfolyás. RO: Debit apă. BG: Воден поток. RU: Расход воды. ET: Veevool. LV: Ūdens plūsma. LT: Vandens srautas. JA: 流水. ZH: 水流量 KO: 급수량 TH: การไหลของน้ำ MS: Aliran air.
10			EN: High pressure nozzle DE: Hochdruckdüse. FR: Buse haute pression. NL: Hogedruksproeier. IT: Ugello alta pressione. NO: Høytrykksmunnstykke. SV: Högtrycksmunstycke. DA: Højtryksdyse. FI: Korkeapainesuutin. ES: Boquilla de alta presión. PT: Bocal de alta pressão. EL: Ακροφύσιο υψηλής πίεσης. TR: Yüksek basınçlı ağız. SL: Šoba za visoki pritisk. HR: Visokotlačna mlaznica. SK: Vysokotlaková hubica. CS: Vysokotlaková tryska. PL: Dysza wysokociśnieniowa. HU: Nagynyomású fúvóka. RO: Duză de înaltă presiune. BG: Дюза за високо налягане. RU: Сопло высокого давления. ET: Kõrgsurve otsak. LV: Augstspiediena sprausla. LT: Aukšto slėgio purkštukas. JA: 高压カノズル. ZH: 高压喷嘴. KO: 고압 노즐 TH: หัวฉีดแรงดันสูง MS: Nozel tekanan tinggi.
11		°C (°F)	EN: Permissible temperature. DE: Zulässige Temperatur. FR: Température autorisée. NL: Toegestane temperatuur. IT: Temperatura ammissibile. NO: Tillatt temperatur. SV: Tillåten temperatur. DA: Maks. temperatur. FI: Sallittu lämpötila. ES: Temperatura admisible. PT: Temperatura permitida. EL: Επιτρεπτή θερμοκρασία. TR: İzin verilen sıcaklık. SL: Dovoljena temperatura. HR: Dopusštena temperatura. SK: Prípustná teplota. CS: Přípustná teplota. PL: Dopuszczalna temperatura. HU: Megengedett hőmérséklet. RO: Temperatură admisă. BG: Допустима температура. RU: Допустимая температура. ET: Lubatud temperatuur. LV: Pieļaujama temperatūra. LT: Leistina temperatūra. JA: 許容温度. ZH: 允许温度. KO: 허용 온도. TH: อุณหภูมิที่ใช้งานได้ MS: Suhu yang dibenarkan.

12		<p>°C (°F)</p>	<p>EN: Max water inlet temperature, Intake-Pressure operation. DE: Max Wassereinlassstemperatur - Druckbetrieb. FR: Température max. de l'entrée d'eau en mode admission/pression. NL: Max. Waterinlaattemperatuur Inlaat-Tijdens. Bedrijf. IT: Temperatura max. alimentazione acqua Funzionamento a ingressopressione. NO: Maks. temperatur vanninntak, Inntakstrykk drift. SV: Max ingående vattentemperatur inlopps-tryckdrift. DA: Maks. vandtilgangstemperatur, tilgangstrykdrift. FI: Tuloveden suurin lämpötila, käytettäessä painepesurina. ES: Temperatura y presión máxima de entrada del agua. PT: Temperatura máxima de entrada de água, Funcionamento da pressão de entrada. EL: Μεγ. θερμοκρασία εισόδου νερού-λειτουργίας πίεσης. TR: Maks. su girişi sıcaklığı Emme-Basınçlı çalışma. SL: Najv. vstopna temperatura vode, vstopni tlak pri delovanju. HR: Maks. temperatura ulazne vode, tlak pri usisavanju. SK: Max. vstupná teplota vody, Prevádzka v nasávacom režime pod tlakom. CS: Max. teplota vody na vstupu, provozní sací tlak. PL: Maks. temperatura na dopływie wody z instalacji wodociągowej. HU: Max. bemenő vízhőmérséklet Szívónyomásos üzem. RO: Temperatura max. de admisie apă în cazul alimentării de la robinet. BG: Макс. температура на входящата вода – работа в режим на засмукване. RU: Макс. температура воды на входе (всасывание/подача под давлением). ET: Max vee sisselasketemperatuur Sissevõturihk töö ajal. LV: Maks. ūdens ieplūdes temperatūra ieplūdes-spiediena darbībā. LT: Didžiausia vandens paėmimo temperatūra, veikimas esant jėjimui slėgiui. JA: 最高流入水温度、吸気圧力動作。 ZH: 进水压力操作时的最高进水水温 KO: 최대 급수 온도 주입/압력 작동. TH: อุณหภูมิน้ำเข้าสูงสุด ความดันในการใช้งานบริเวณทางเข้า MS: Suhu maksimum air masuk, Kemasukan-Operasi tekanan.</p>
13		<p>bar (MPa) Бар (МПа) 巴 (兆帕)</p>	<p>EN: Max. water inlet pressure. DE: Max. Wassereinlassdruck. FR: d'eau en mode admission/pression. NL: Max. waterinlaatdruk. IT: Pressione max. alimentazione acqua. NO: Maks. trykk vanninntak. SV: Max tryck för vatteninlopp. DA: Maks. Vandtilgangstryk. FI: Tuloveden suurin paine. ES: Presión máxima de entrada del agua. PT: Pressão máxima de entrada de água. EL: Μεγ. πίεση εισόδου νερού. TR: Maks. su girişi basıncı. SL: Najv. tlak dovoda vode. HR: Maks. tlak ulazne vode. SK: Max. vstupný tlak vody. CS: Max. tlak vody na vstupu. PL: Maks. ciśnienie na dopływie wody. HU: Max. bemenő nyomás. RO: Presiunea max. de alimentare cu apă. BG: Макс. налягане на входяща вода. RU: Макс. давление воды на входе. ET: Maks vee sissevoolusurve. LV: Maks. ūdens spiediens. LT: Didžiausias vandens paėmimo slėgis. JA: 最高流入水圧。 ZH: 最大进水压力 KO: 최고 급수 압력. TH: ความดันน้ำเข้าสูงสุด MS: Tekanan maksimum air masuk.</p>
14		<p>mm 毫米</p>	<p>EN: Dimensions LxWxH. DE: Masse LxBxH. FR: Dimensions l x p x h. NL: Afmetingen LxBxH. IT: Dimensioni, lun. x larg. x alt. NO: Mål LxBxH. SV: Dimensioner LxBxH. DA: Mål LxBxH. FI: Mitat, PxLxK. ES: Dimensiones l x a x al. PT: Dimensões, C x L x A. EL: Διαστάσεις, Μ x Π x Υ. TR: Boyutlar, u x g x y. SL: Mere D x Š x V. HR: Dimenzije DxŠxV. SK: Rozmery D x Š x V. CS: Rozměry d x š x v. PL: Wymiary długość x szer. x wys. HU: Méretek H x Sz x M. RO: Dimensiuni. L x l x î. BG: Размери Д x Ш x В. RU: Размеры, Дл. x Шир. x Выс. ET: Mõõtmed p x l x k. LV: Izmēri G x P x A. LT: Matmenys (l x p x a). JA: 外形寸法長さx幅x高さ。 ZH: 尺寸 (长 x 宽 x 高) 毫米 KO: 크기 (l x w x h). TH: ขนาด ยาว x กว้าง x สูง MS: Dimensi LxWxH.</p>
15		<p>kg кг</p>	<p>EN: Weight. DE: Gewicht. FR: Poids du nettoyeur. NL: Gewicht van de hogedrukreiniger. IT: Peso dell'idropulitrice. NO: Vekt høytrykksvasker. SV: Maskinens vikt. DA: Vægt. FI: Pelkän painepesurin paino. ES: Peso del limpiador. PT: Peso da máquina de limpeza. EL: Βάρος μηχανήματος καθαρισμού. TR: Temizlik makinesinin yüksekliği. SL: Masa. HR: Težina. SK: Hmotnosť. CS: Hmotnost čisticího stroje. PL: Ciężar myjki. HU: Tisztítógép tömege. RO: Greutatea aparatului. BG: Тегло. RU: Вес моечной машины. ET: Pesuri kaal. LV: Tīrītāja svars. LT: Valymo įrenginio svoris. JA: 重量。 ZH: 清洗机重量 KO: 세척기 무게. TH: น้ำหนัก MS: Berat.</p>

16	 (IEC 60335-2-79)	dB(A) дБ(А)	EN: Sound pressure level L_{PA} DE: Schalldruckpegel FR: Niveau de pression acoustique NL: Geluidsdruk niveau IT: Livello pressione sonora NO: Lydtrykknivå SV: Ljudtrycksnivå DA: Lydtryksniveau FI: Äänenpainetaso ES: Nivel de presión sonora PT: Nível de pressão acústica EL: Επίπεδο πίεσης ήχου TR: Göre ses basıncı seviyesi SL: Raven zvočnega tlaka. HR: Razina zvučnog tlaka. SK: Hladina zvukového. CS: Hladina akustického tlaku PL: Poziom ciśnienia akustycznego HU: Hangnyomás szint RO: Nivel de presiune acustică BG: Ниво на звуково налягане RU: Уровень шума ET: Helisurve tase LV: Akustiskā spiediena līmenis LT: Garso slėgio lygis JA: 音圧レベル ZH: 声压级 KO: 음압 레벨 TH: ระดับความดันเสียง MS: Tahap tekanan bunyi
17	 (IEC 60335-2-79)	dB(A) дБ(А)	EN: Sound power level L_{WA} DE: Schalleistungspegel FR: Niveau de puissance acoustique NL: Geluidsvermogen niveau IT: Livello potenza sonora NO: Lydeffektnivå SV: Ljudeffektnivå DA: Lydeffektniveau FI: Äänen tehotaaso ES: Potencia acústica PT: Nível de potência acústica EL: Επίπεδο ισχύος ήχου TR: Göre ses basıncı seviyesi SL: Raven moči zvoka. HR: Razina jakosti. SK: Hladina zvukového výkonu. CS: Hladina akustického výkonu PL: Poziom mocy akustycznej HU: Hangteljesítmény szint RO: Nivelul de putere acustică BG: Ниво на звукова мощност RU: Уровень звуковой мощности ET: Helivõimsuse tase LV: Akustiskās jaudas līmenis LT: Garso galios lygis JA: 音響パワーレベル ZH: 声功率级 KO: 소음 레벨 TH: ระดับกำลังเสียง MS: Tahap kuasa bunyi
18	 (ISO 5349 a _h)	m/s² 米/秒²	EN: Vibration. DE: Vibrationen FR: Vibration NL: Vibratie IT: Vibrazioni NO: Vibrasjoner SV: Vibration DA: Vibration FI: Tärinäarvot ES: Vibración PT: Vibração EL: Δόνηση TR: Titreşimi SL: Vibracije. HR: Vibracije. SK: Vibrácie. CS: Vibrace PL: Drgania HU: Vibráció RO: Vibrații BG: Вибрации. RU: Вибрация ET: vibratsioon LV: vibrācija LT: Vibracijos JA: 振動. ZH: 振动 KO: 진동 TH: แรงสั่นสะเทือน MS: Getaran.
19		N	EN: Recoil forces, lance. DE: Rückstoßkraft, Sprühhrohr FR: Forces de recul, lance NL: Terugslagkracht, lans IT: Forze di rinculo, lancia NO: Rekylkraft, lanse SV: Rekylkraft, spolrör DA: Rekylkraft, dyserør FI: Rekyylivoimat, suutin ES: Fuerzas de retroceso, lanza PT: Forças de retrocesso, lança EL: Δυνάμεις οπισθοδρόμησης, διάταξη ψεκασμού χη. TR: Sarmal kuvvetler, boru SL: Povratne sile, šoba. HR: Trzajne sile, mlaznica. SK: Spätňý odraz, štandardná striekacia rúra. CS: Síly zpětného rázu, násadec PL: Siły odrzutu, lanca HU: Visszaható erő, szórócső RO: Forțe de recul, tijă BG: Сили на откат, крайник. RU: Сила отдачи (распылитель). ET: Tagasilöögi jõud, otsik LV: Atsitiena spēks, smidzinātājs LT: Atatrankos jėga, antgalis. JA: 反跳力、ランス。 ZH: 反冲力 (喷杆) KO: 반동력, 랜스 TH: แรงสะท้อนถอยหลัง, ปลายทอ MS: Kuasa sentakan, lans.
20		L л 升	EN: Oil quantity, type. DE: Ölmenge, typ. FR: Quantité d'huile, type. NL: Hoeveelheid olie, type. IT: Quantità di olio, tipo. NO: Oljemengde, type. SV: Oljemängd, typ. DA: Oliemængde, type. FI: Öljymäärä, tyyppi. ES: Cantidad de aceite, tipo. PT: Quantidade de óleo, tipo. EL: Ποσότητα λαδιού, τύπος. TR: Yağ miktarı, tipi. SL: Količina olja, vrsta. HR: Količina ulja, vrsta. SK: Množstvo oleja, typ. CS: Množství oleje, typ. PL: Mnożstwo oleje, typ. HU: Olajmennyiség, típusa. RO: Cantitate de ulei, tip. BG: Количество масло, Тип. RU: Количество масла, Тип. ET: õli kogus, tüüp. LV: Eļļas daudzums, tips. LT: alyvos kiekis, tipas. JA: オイル量種類. ZH: 猴祇 类型 KO: 오일량, 유형. TH: ปริมาณน้ำมันเครื่อง ประเภท MS: Kuantiti minyak, jenis.
21		kW кВт	EN: Heating capacity. DE: Heizleistung. FR: Puissance calorifique. NL: Verwarmingscapaciteit. IT: Potenza termica. NO: Varmekapasitet. SV: Värmeeffekt. DA: Opvarmningskapacitet. FI: Lämmitysteho. ES: Capacidad de calentamiento. PT: Capacidade de aquecimento. EL: Θερμική απόδοση. TR: Isıtma kapasitesi. SL: Zmogljivost gretja. HR: Kapacitet grijanja. SK: Ohrevný výkon. CS: Tepelný výkon. PL: Moc grzewcza. HU: Fűtőteljesítmény. RO: Capacitate de încălzire. BG: Отоплителна мощност. RU: Мощность нагрева. ET: Küttevõimsus. LV: Sildīšanas jauda. LT: Šildymo galia. JA: 加熱能力. ZH: 热容量. KO: 가열 용량. TH: ความจุความร้อน MS: Kapasiti pemanasan.

22		L л 升	<p>EN: Fuel tank. DE: Kraftstofftank. FR: Réservoir de carburant. NL: Brandstoftank. IT: Serbatoio carburante. NO: Drivstoffbeholder. SV: Bränsletank. DA: Brændstoftank. FI: Polttoainesäiliö. ES: Depósito de combustible. PT: Depósito de combustível. EL: Πεζεβουάρ καυσίμου. TR: Yakıt deposu. SL: Posoda za gorivo. HR: Spremnik goriva. SK: Palivová nádrž. CS: Palivová nádrž. PL: Zbiornik paliwa. HU: Üzemanyagtartály. RO: Rezervor de combustibil. BG: Резервоар за гориво. RU: Топливный бак. ET: Kütusepaak. LV: Degvielas tvertne. LT: Kuro bakas. JA: 燃料タンク。 ZH: 油箱。 KO: 연료 탱크. TH: ถังเชื้อเพลิง MS: Tangki bahan api.</p>
23		L л 升	<p>EN: Detergent tank A/B. DE: Reinigungsmittelbehälter A/B. FR: Réservoir de détergent A/B. NL: Reinigingsmiddeltank A/B. IT: Serbatoio del detergente A/B. NO: Vaskemiddelbeholder A/B. SV: Tank för rengöringsmedel A/B. DA: Rengøringsmiddeltank A/B. FI: Pesuainesäiliö A/B. ES: Depósito de detergente A/B. PT: Depósito de detergente A/B. EL: Πεζεβουάρ απορρυπαντικών A/B. TR: Deterjan deposu A/B. SL: Posoda za detergent A/B. HR: Spremnik za deterđent A/B. SK: NádoĎa na čistiaci prostriedok A/B. CS: Nádrž na čisticí prostředek A/B. PL: Zbiornik na plyn do czyszczenia A/B. HU: Tisztítószerartály A/B. RO: Rezervor de detergent A/B. BG: Резервоар за почистващ препарат A/B. RU: Бак с моющим средством A/B. ET: Puhastusvahendi paak A/B. LV: Mazgāšanas līdzekļu tvertne A/B. LT: Ploviklio bakas A/B. JA: 洗剤タンクA/B. ZH: 洗涤剂箱 A/B. KO: 세제 탱크 A/B. TH: ถังสารซักฟอก A/B MS: Tangki detergent A/B.</p>
24	<p>EN: Specifications and details are subject to change without prior notice. DE: Technische Daten und Details des Geräts können sich ohne vorherige Ankündigung ändern. FR: Ces spécifications et détails sont susceptibles d'être modifiés sans préavis. NL: Specificaties en details kunnen zonder voorafgaande waarschuwing worden gewijzigd. IT: Specifiche e dettagli sono soggetti a modifiche senza preavviso. NO: Spesifikasjonene og detaljene er gjenstand for endringer uten forutgående varsel. SV: Specifikationer och information kan ändras utan föregående meddelande. DA: Ret til ændringer i konstruktion og specifikationer forbeholdes. FI: Rakenteeseen ja teknisiin tietoihin voidaan tehdä muutoksia ilmoittamatta niistä ennalta. ES: Las especificaciones y los datos están sujetos a cambios sin previo aviso. PT: As especificações e os detalhes estão sujeitos a alterações sem aviso prévio. EL: Τα τεχνικά χαρακτηριστικά και οι λεπτομέρειες υπόκεινται σε αλλαγές χωρίς προηγούμενη ειδοποίηση. TR: Özellikler ve ayrıntılar, önceden haber verilmeden değıştirilebilir. SL: Tehnični podatki in podrobnosti se lahko spremenijo brez predhodnega obvestila. HR: Specifikacije i detalji mogu se mijenjati bez prethodne najave. SK: Špecifikácie a podrobnosti sa môžu meniť bez predchádzajúceho upozornenia. CS: Technické údaje a detaily mohou být změněny i bez předchozího upozornění. PL: Specyfikacje i parametry mogą zostać zmienione bez uprzedzenia. HU: A műszaki adatok és részletek előzetes értesítés nélkül megváltozhatnak. RO: Specificațiile și detaliile pot fi modificate fără înștiințare prealabilă. BG: Спецификациите и детайлите подлежат на промяна без предварително уведомление. RU: Технические характеристики и данные могут изменяться без предварительного извещения. ET: Tehnilisi kirjeldusi ja üksikasju võidakse muuta eelneva etteteatamiseta. LV: Specifikācijas un detaļas var tikt mainītas bez iepriekšēja paziņojuma. LT: Konstrukcija ir specifikacijos gali keistis be išankstinio įspėjimo. JA: 仕様および情報は事前通知無しに変更する場合があります。 ZH: 规格和详情如有变更，恕不另行通知。 KO: 사양 및 내용은 예고없이 변경될 수 있습니다. TH: ข้อกำหนดเฉพาะและรายละเอียดสามารถเปลี่ยนแปลงได้โดยไม่ต้องแจ้งให้ทราบล่วงหน้า MS: Spesifikasi dan butiran adalah tertakluk kepada perubahan tanpa notis terlebih dahulu.</p>		



HEAD QUARTER

DENMARK

Nilfisk A/S
Kornmarksvej 1
DK-2605 Broendby
Tel.: (+45) 4323 8100
www.nilfisk.com

SALES COMPANIES

ARGENTINA

Nilfisk srl.
Edificio Central Park
Herrera 1855, 6th floor/604
Ciudad de Buenos Aires
Tel.: (+54) 11 6091 1571
www.nilfisk.com.ar

AUSTRALIA

Nilfisk Pty Ltd
Unit 1/13 Bessemer Street
Blacktown NSW 2148
Tel.: (+61) 2 98348100
www.nilfisk.com.au

AUSTRIA

Nilfisk GmbH
Metzgerstrasse 68
5101 Bergheim bei Salzburg
Tel.: (+43) 662 456 400 90
www.nilfisk.at

BELGIUM

Nilfisk n.v.-s.a.
Riverside Business Park
Boulevard Internationalelaan 55
Bâtiment C3/C4 Gebouw
Bruxelles 1070
Tel.: (+32) 14 67 60 50
www.nilfisk.be

BRAZIL

Nilfisk do Brasil
Av. Eng. Luis Carlos Berrini, 550
40 Andar, Sala 03
SP - 04571-000 Sao Paulo
Tel.: (+11) 3959-0300 / 3945-4744
www.nilfisk.com.br

CANADA

Nilfisk Canada Company
240 Superior Boulevard
Mississauga, Ontario L5T 2L2
Tel.: (+1) 800-668-8400
www.nilfisk.ca

CHILE

Nilfisk S.A. (Comercial KCS Ltda)
Salar de Llamara 822
8320000 Santiago
Tel.: (+56) 2684 5000
www.nilfisk.cl

CHINA

Nilfisk
4189 Yindu Road
Xinzhuang Industrial Park
201108 Shanghai
Tel.: (+86) 21 3323 2000
www.nilfisk.cn

CZECH REPUBLIC

Nilfisk s.r.o.
VGP Park Horní Počernice
Do Čertous 1/2658
193 00 Praha 9
Tel.: (+420) 244 090 912
www.nilfisk.cz

DENMARK

Nilfisk Danmark A/S
Industrivej 1
Hadsund, DK-9560
Tel.: 72 18 21 20
www.nilfisk.dk

FINLAND

Nilfisk Oy Ab
Koskelontie 23 E
02920 Espoo
Tel.: (+358) 207 890 600
www.nilfisk.fi

FRANCE

Nilfisk SAS
26 Avenue de la Baltique
Villebon sur Yvette
91978 Courtabouef Cedex
Tel.: (+33) 169 59 87 00
www.nilfisk.fr

GERMANY

Nilfisk GmbH
Guido-Oberdorfer-Straße 2-10
89287 Bellenberg
Tel.: (+49) (0)7306/72-444
www.nilfisk.de

GREECE

Nilfisk A.E.
Αναπαύσεως 29
Κορωπί T.K. 194 00
Tel.: (30) 210 9119 600
www.nilfisk.gr

HOLLAND

Nilfisk B.V.
Versterkerstraat 5
1322 AN Almere
Tel.: (+31) 036 5460760
www.nilfisk.nl

HONG KONG

Nilfisk Ltd.
2001 HK Worsted Mills
Industrial Building
31-39, Wo Tong Tsui St.
Kwai Chung, N.T.
Tel.: (+852) 2427 5951
www.nilfisk.com

HUNGARY

Nilfisk Kft.
II. Rákóczi Ferenc út 10
2310 Szigetszentmiklós-Lakihegy
Tel.: (+36) 24 475 550
www.nilfisk.hu

INDIA

Nilfisk India Limited
Pramukh Plaza, 'B' Wing, 4th floor, Unit
No. 403
Cardinal Gracious Road, Chakala
Andheri (East) Mumbai 400 099
Tel.: (+91) 22 6118 8188
www.nilfisk.in

IRELAND

Nilfisk
1 Stokes Place
St. Stephen's Green
Dublin 2
Tel.: (+35) 3 12 94 38 38
www.nilfisk.ie

ITALY

Nilfisk SpA
Strada Comunale della Braglia, 18
26862 Guardamiglio (LO)
Tel.: (+39) (0) 377 414021
www.nilfisk.it

JAPAN

Nilfisk Inc.
1-6-6 Kita-shinyokohama, Kouhoku-ku
Yokohama, 223-0059
Tel.: (+81) 45548 2571
www.nilfisk.com

MALAYSIA

Nilfisk Sdn Bhd
Sd 33, Jalan KIP 10
Taman Perindustrian KIP
Sri Damansara
52200 Kuala Lumpur
Tel.: (60) 3603 627 43 120
www.nilfisk.com

MEXICO

Nilfisk de Mexico, S. de R.L. de C.V.
Pirineos #515 Int.
60-70 Microparque
Industrial WSantiago
76120 Queretaro
Tel.: (+52) (442) 427 77 00
www.nilfisk.com

NEW ZEALAND

Nilfisk Limited
Suite F, Building E
42 Tawa Drive
0632 Albany Auckland
Tel.: (+64) 9 414 1996
Website: www.nilfisk.com

NORWAY

Nilfisk AS
Bjørnerudveien 24
1266 Oslo
Tel.: (+47) 22 75 17 80
www.nilfisk.no

PERU

Nilfisk S.A.C.
Calle Boulevard 162, Of. 703, Lima 33-
Perú
Lima
Tel.: (511) 435-6840
www.nilfisk.com

POLAND

Nilfisk Sp. Z.O.O.
Millenium Logistic Park
ul. 3 Maja 8, Bud. B4
05-800 Pruszków
Tel.: (+48) 22 738 3750
www.nilfisk.pl

PORTUGAL

Nilfisk Lda.
Sintra Business Park
Zona Industrial Da Abrunheira
Edificio 1, 1° A
P2710-089 Sintra
Tel.: (+351) 21 911 2670
www.nilfisk.pt

RUSSIA

Nilfisk LLC
Vyatskaya str. 27, bld. 7/1st
127015 Moscow
Tel.: (+7) 495 783 9602
www.nilfisk.ru

SINGAPORE

Den-Sin
22 Tuas Avenue 2
639453 Singapore
Tel.: (+65) 6268 1006
www.densin.com

SLOVAKIA

Nilfisk s.r.o.
Bancíkovej 1/A
SK-821 03 Bratislava
Tel.: (+421) 910 222 928
www.nilfisk.sk

SOUTH AFRICA

Nilfisk (Pty) Ltd
Kimbult Office Park
9 Zeiss Road
Laser Park
Honeydew
Johannesburg
Tel: +27118014600
www.nilfisk.co.za

SOUTH KOREA

Nilfisk Korea
3F Duksoo B/D, 317-15
Sungsoo-Dong 2Ga
Sungdong-Gu, Seoul
Tel.: (+82) 2497 8636
www.nilfisk.co.kr

SPAIN

Nilfisk S.A.
Torre d'Ara,
Passeig del Rengle, 5 Plta. 10ª
08302 Mataró
Tel.: (34) 93 741 2400
www.nilfisk.es

SWEDEN

Nilfisk AB
Taljegårdsgatan 4
431 53 Mölndal
Tel.: (+46) 31 706 73 00
www.nilfisk.se

SWITZERLAND

Nilfisk AG
Ringstrasse 19
Kircheberg/Industri Stelz
9500 Wil
Tel.: (+41) 71 92 38 444
www.nilfisk.ch

TAIWAN

Nilfisk Ltd
Taiwan Branch (H.K)
No. 5, Wan Fang Road
Taipei
Tel.: (+88) 6227 00 22 68
www.nilfisk.tw

THAILAND

Nilfisk Co. Ltd.
89 Soi Chokechai-Ruammitr
Viphavadee-Rangsit Road
Ladyao, Jatuchak, Bangkok 10900
Tel.: (+66) 2275 5630
www.nilfisk.co.th

TURKEY

Nilfisk A.S.
Serifali Mh. Bayraktar Bulv. Sehit Sk. No:7
Ümraniye, 34775 Istanbul
Tel.: +90 216 466 94 94
www.nilfisk.com.tr

UNITED ARAB EMIRATES

Nilfisk Middle East Branch
SAIF-Zone
P.O. Box 122298
Sharjah
Tel.: (+971) (0) 655-78813
www.nilfisk.com

UNITED KINGDOM

Nilfisk Ltd.
Nilfisk House, Bowerbank Way
Gilwilly Industrial Estate, Penrith
Cumbria CA11 9BQ
Tel.: (+44) (0) 1768 868995
www.nilfisk.co.uk

UNITED STATES

Nilfisk, Inc.
9435 Winnetka Ave N,
Brooklyn Park
MN- 55445
www.nilfisk.com

VIETNAM

Nilfisk Vietnam
No. 51 Doc Ngu Str.
P. Vinh Phúc, Q.Ba Dinh
Hanoi
Tel.: (+84) 761 5642
www.nilfisk.com