

FR95

USER MANUAL IN ORIGINAL

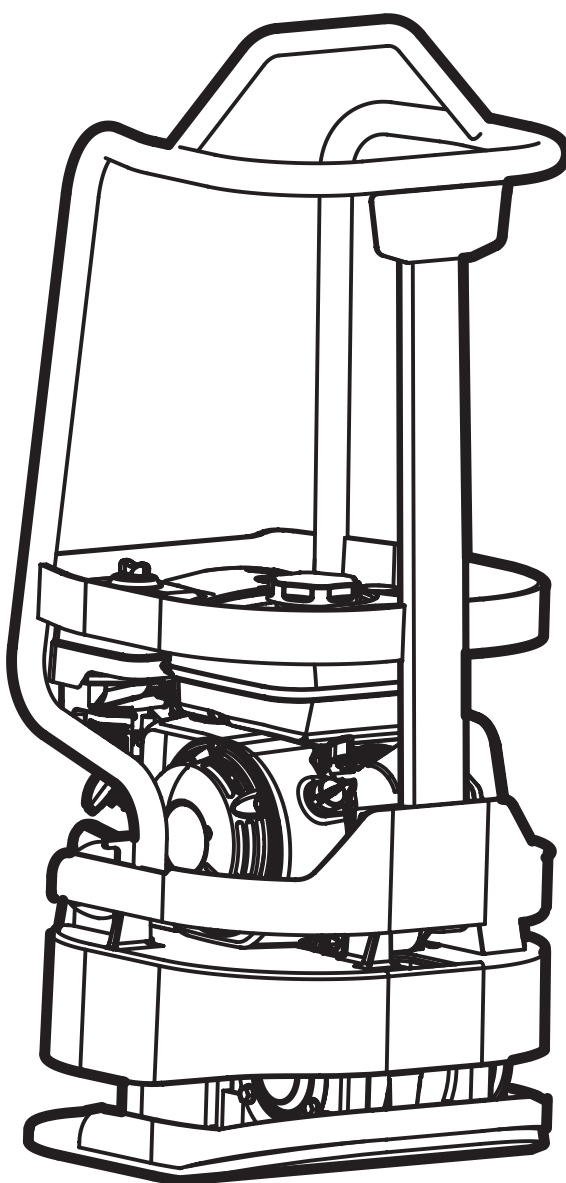

USE

SWEPAC FR 95

is used to pack ballast under foundations, on pavements, in trenches, etc. The rounded base plate makes the machine very suitable for packing around pillars, foundations, wells, etc. In places with poor access, for example in pipe and cable trenches, the machine is easy to use. The machine is suitable for packing sand and gravel in thin layers.

CONTENTS

USE.....	3
SAFETY INSTRUCTIONS.....	4
STANDARDS.....	4
SIGNS.....	5
TECHNICAL DATA.....	6
METHOD OF OPERATION	6
TECHNICAL DESCRIPTION	7
DAILY SUPERVISION	8
BEFORE STARTING.....	9
STARTING.....	9
AFTER STARTING.....	9
STOPPING	9
DIMENSIONS.....	10
DRIVING INSTRUCTIONS.....	11
TRANSPORTATION.....	11
NOTES.....	12; 13; 14
EC-DECLARATION OF CONFORMITY.....	15

SAFETY INSTRUCTIONS

- Before using the machine, the operator must be informed of the manufacturer's safety instructions and instructions for use.
- The machine may only be used outdoors.
- The machine may not be used if protection and safety devices are not present or not working.
- The operator may not leave the machine unattended when the engine is on. When the vibrator is connected, the operator must be able to control the movement of the machine using the operating lever and the start/stop controls. The machine may only be operated by a trained operator.
- During maintenance work or other interventions in the machine, the engine must always be off.
- Switch the engine off before adding fuel. Avoid fuel spillage and immediately wipe off any spilled fuel. Add fuel only in well ventilated areas.
- Avoid touching hot engine parts, for example the silencer.
- Before lifting the machine, check that the lifting device and its mounting are not damaged and that the rubber dampers on the base plate are undamaged and tightened.
- During transportation and storage, the fuel tank should be empty and the fuel cock switched off.
- When the machine is parked, ensure that it cannot tip over. The machine must not incline more than 20°. (FR 95 18°)
- The operator must use ear protectors when working with the machine.
- The operator must ensure that no unauthorised persons are in the immediate vicinity of the machine.
- Always wear personal protective equipment as heavy, non-slip shoes, ear protectors and approved eye protection.
- The machine may not be used in environments with potential fire or explosion danger.
- Never use the machine if you are tired or have consumed alcohol or are using medication that could affect your vision, your discretion or your coordination ability.
- Never use a machine that, in any way, has been changed from its original design.

STANDARDS

Noise

Measurement according to the standard EN 500-4 Rev.1: 1998, Annex C: Measurement uncertainty $\pm 0,5\text{dB (A)}$ i 95% of measurements.

In accordance with the conditions in Directive 2000/14/EC, Annex VI, the following values are reported:

Sound pressure level at the operator's ears, L _{pA}	90dB (A)
Permitted sound power level, L _{WA}	105 dB (A)
Guaranteed sound power level, L _{WA}	105 dB (A)

As the sound pressure level at the operator's ears exceeds 80 dB (A), ear protectors must be used during operation!

Hand/arm vibration

Vibration acceleration has been measured according to the ISO 5349 standard when driving on gravel substrates. The measured values have been converted to maximum daily exposure during regular use. Further information is available in the work environment regulations AFS 2005:15 on vibration, valid from 1 July 2005.

Measurement uncertainty $\pm 0,3 \text{ m/s}^2$ in 95% of measurements.

	FR 95
Hand/arm-vibrations m/s ²	< 2,5
Maximum daily exposure	5,2 tim

Exhaust Emissions

The machines meet the requirements for exhaust emissions in accordance with Euro V.

Additional information

Environmentally approved for use in large cities.

SIGNS

Warning Signs

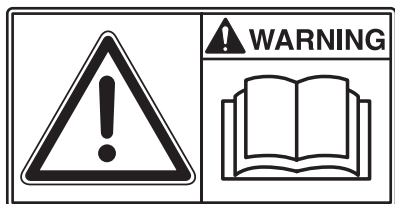

Before use, carefully read through the manual and safety regulations in order to be able to handle the machine in a proper manner. Make sure that the handbook is always available



Engine, silencer: To avoid burns or discomfort, do not touch hot engine parts when the engine is on or when the machine has recently been used.



Belt drive: Keep hands, tools or other objects away from the belt drive when the machine is in operation in order to avoid injury.
See the safety instructions in the manual.



As the sound pressure level at the operator's ears exceeds 80 dB (A), ear protectors must be used during operation to prevent hearing damage.

Machine plate

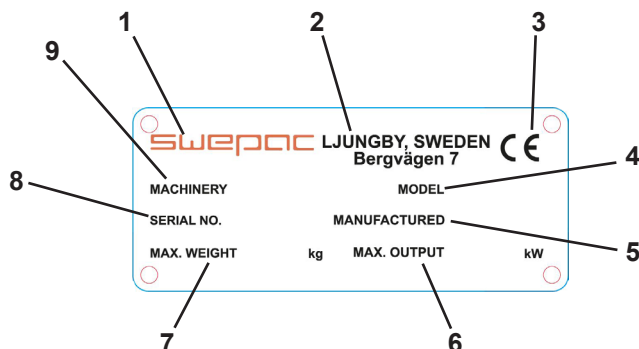

1. Manufacturer.
2. Country of manufacture.
3. CE label.
4. Model name.
5. Year of manufacture.
6. Maximum motor power.
7. Maximum weight.
8. Serial number.
9. Machine type.

TECHNICAL DATA

FR 95

Net weight.....	89 kg
Base plate,w x l	430 x 435 mm
Operational speed approximately	25 m/min
Permitted inclination	18°
Centrifugal force	14,000 N
Vibration frequency	91 Hz
Drive engine	HondaGX 160
Engine power	3,6 kW
Engine RPM	3600 RPM
Fuel tank volume	3,1 litre
Fuel type	Unleaded petrol, 95-98 octane
Oil quantity, crankcase	0,6 litre

OIL and FUEL RECOMMENDATIONS

FuelUnleaded petrol or alkylate
 Engine oil SAE10W-30
 Engine oil change: first oil change after 20 hours then every 100 hours of operation.

Note! Vibration element for the FR95 is grease lubricated. The bearing can not be re-greased, and is permanently lubricated.
 This means that no oil is needed for the vibration element.

METHOD OF OPERATION

The machine consists of a base plate with vibrating elements and a top-mounted suspended plate. The cushioning between the base plate and the upper part consists of rubber dampers. The power is transmitted from the petrol engine to the vibration element via a V-belt which can be adjusted with a belt tensioner. The engine V-belt pulley is fitted with an integrated centrifugal clutch, which allows the engine to be started and run idle without the vibrator being connected. On account of the direction of rotation and the position of the vibration element at the front end of the base plate, the vibrator moves forwards under its own power. The petrol engine is well protected against damage in connection with use and transportation by a sturdy protective frame with a protective panel on the top.

TECHNICAL DESCRIPTION

FR 95

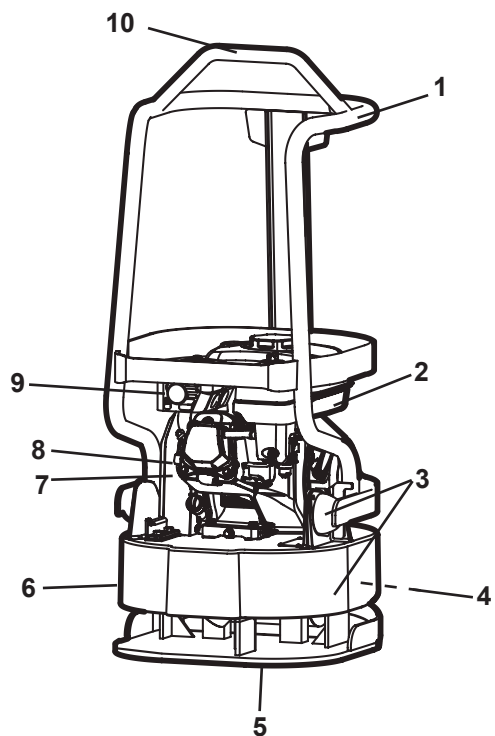

1. Operating lever
2. Petrol engine
3. Rubber dampers
4. Vibrating element
5. Bottom plate
6. Engine plate
7. V-Belt
8. Centrifugal clutch
9. Protective silencer
10. Lifting eye

DAILY SUPERVISION

Fuel Check

Check that there is fuel in the tank. Top up if necessary.

Engine Oil Level Check

Check the oil level in the crankcase every day. The oil must reach the edge of the filling hole when the machine is on a level surface.

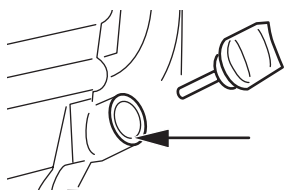

Air Filter Check

The air filter must be checked at least once every working week. When working in dusty conditions, check daily.

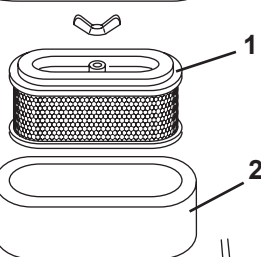
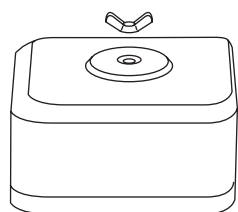

1. Paper element
 2. Foam plastic element
 3. Rubber washer
- Note: Important!

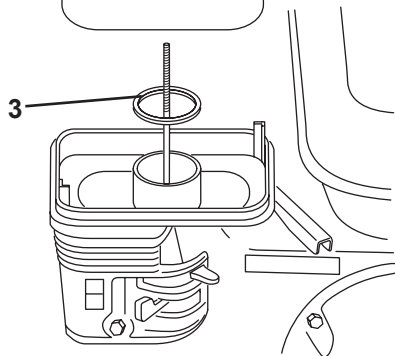

Oil/Fuel Leakage

Check every day that the engine is not leaking oil or fuel. If a leak is discovered, the machine may not be operated until the fault has been remedied.

See also the separate engine instructions!

V-belt drive

Check the tension and condition of the V-belt regularly. Replace a damaged V-belt with a new type SPA 807 for FR 95.

To increase V-belt tension, do as follows: Loosen the screws that keep the belt guard in place. Remove the belt guard.

Loosen the two screws (pos. 1) which attaches the belt tensioner to the engine plate. Pull the belt tensioner backwards until the belt feels sufficiently tight. Tighten the screws again.

Replace the belt guard.

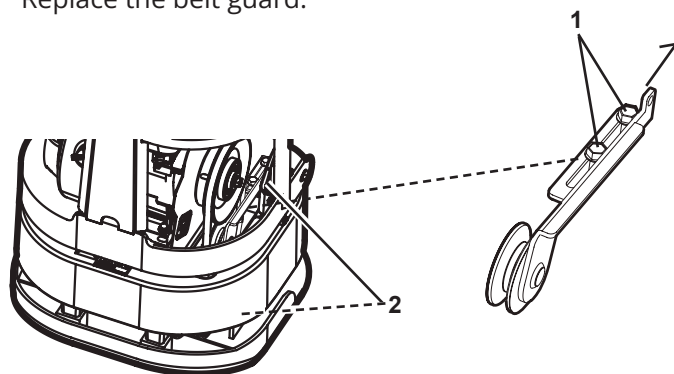

Rubber dampers

Check the condition of the rubber dampers (pos. 1) regularly. Replace damaged dampers.

Cleaning

1. Remove the foam plastic element and the paper element and check that they are undamaged. Replace damaged parts.
2. Wash the foam plastic element in liquid with a high flashpoint and let it dry properly. Dip in engine oil and squeeze dry.
3. Strike the paper element against a hard object a few times to loosen any dirt

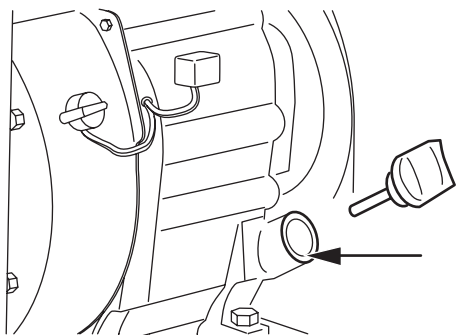

Oil level



Engine power switch

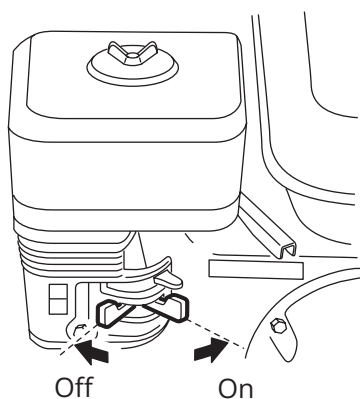

Fuel cock

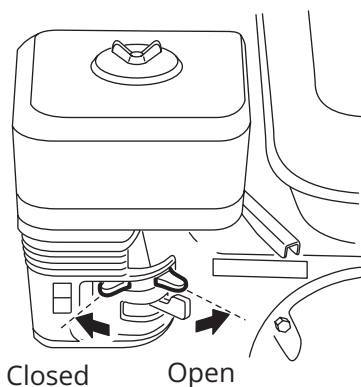

Choke

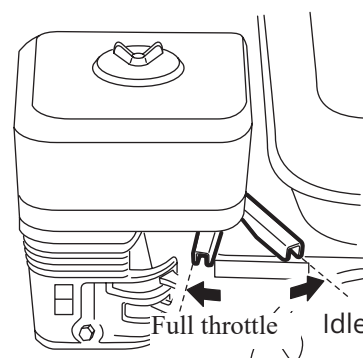

Throttle lever-

BEFORE STARTING

See Daily Supervision, page 8.

STARTING

Switch the engine power switch to "on".

Open the fuel cock.

Switch the throttle lever to 1/3 of full RPM.

Adjust the choke. If the engine is cold, close the choke completely. Do not use the choke if the engine is hot or in hot air temperatures.

Start by pulling the starting lever. Pull it first until the mechanism engages, then pull it hard and fast.

AFTER STARTING

Switch the throttle lever to idle.

Open the choke gradually.

Run the engine for around 5 minutes.

STOPPING

Switch the engine to idle and let it run for a few minutes.

Switch the engine power switch to "off".

Close the fuel cock.

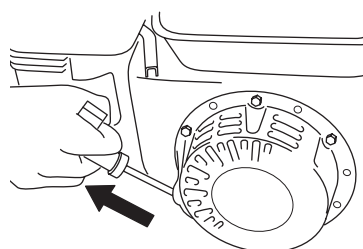

DIMENSIONS in mm

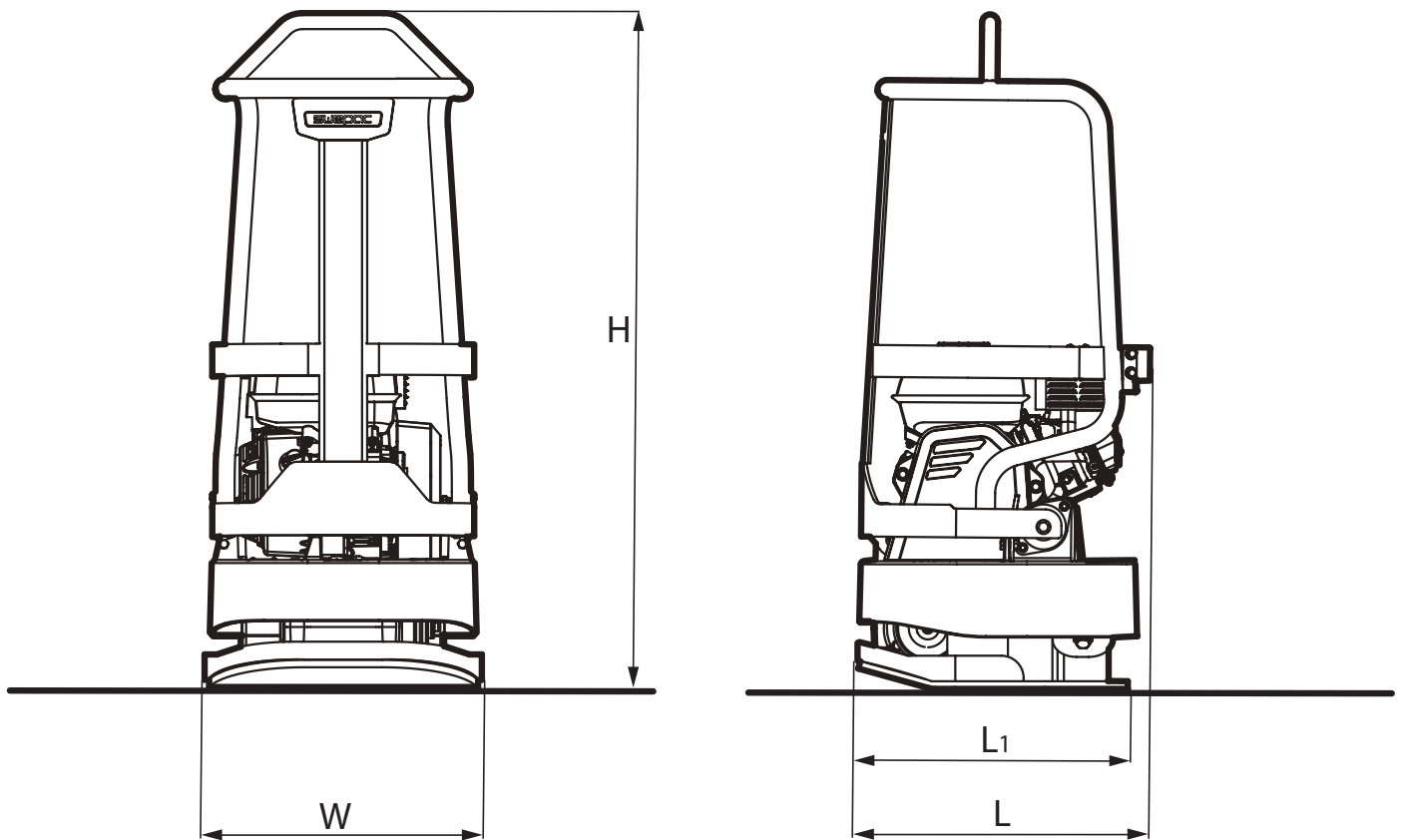

L ₁	430
L	450
W	435
H	1040

DRIVING INSTRUCTIONS

The vibrating element starts when the throttle is increased. The best packing is achieved at full engine RPM. Avoid running the engine at other RPM. The vibrating element of the machine will stop when the throttle switch is set to idling.

The machine is only intended for outdoor use. Operate the machine in daylight or other adequate lighting. Ballast must be wetted or naturally damp. All other uses are advised against.

TRANSPORTATION

The machine has a lifting eye that can be used for a hook or rope.

Check before lifting that the lifting eye and its mounting on the machine are undamaged. Check also that the transport wheels and the base plate's rubber dampers are undamaged and firmly attached.

For transportation by vehicle, the machine must be secured with, for example, approved straps. Note! Note! Secure it by the base plate and not the rubber-cushioned upper part.

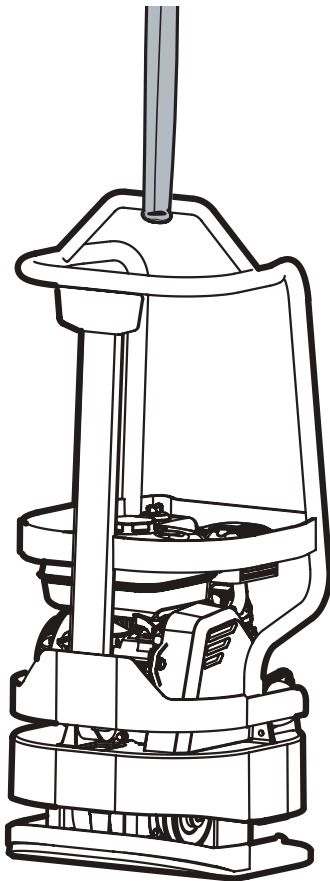
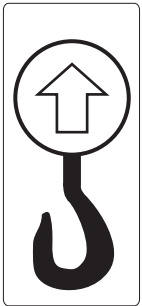
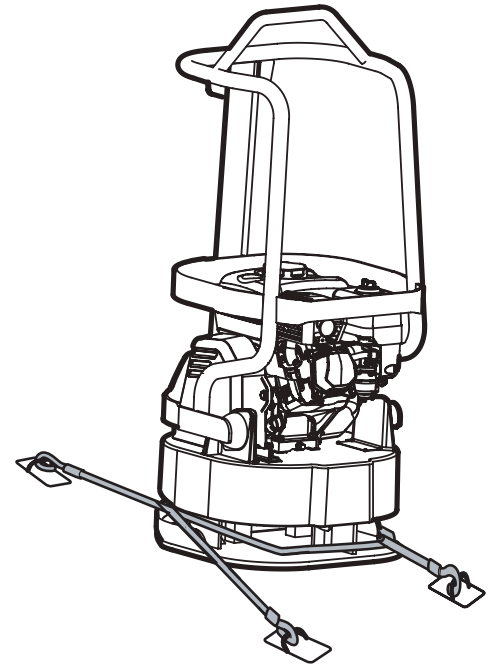

Transport security

Always secure the machine with a strap as shown in the illustration on transport.

NOTES

NOTES

NOTES



EC Declaration of Conformity

Manufacturer

**Swepac AB
Bergvägen 7
34132 Ljungby**

1. Category: Plate compactor
2. Type: FR95
3. Motor power: 3.6 kW

The product complies with the following directives:

2006/42/EC

2000 / 14 /EC

2004/108/EC

EN 500-1

EN 500-4

Technical documentation available from:

Swepac AB, Bergvägen 7 34132 Ljungby SE Tomas Johansson / Product Engineer

SWEPAC

FOR A SOLID GROUND

Bergvägen 7 | SE-341 32 Ljungby | Sweden • Tel +46 (0)372-156 00 | www.swepac.com